



International HAM Magazine - 100% HAM RADIO



Coaxial cable Tester



YO2BS, 50 years on the air!

TABLE OF CONTENTS

YO2BS... 50 years On the air !



[HOMEBREW]

80-40 meters wire antenna

15

DX Calendar

24

Continuous Feed source of 14VO-68

4

Quadrifilar Helix Antennas

31

50MHz - DX News

29

Coaxial cable Tester

6

Comic's HAM

39

Make you own printed circuit

34



[CATEGORIES]

POST IT !

3

[O.M. Discovering]

YO2BS, 50 years on the air

12

MJF-269 Review

17

[HISTORY]

The history of Torre Bert

36

The venerable VTVM

7



DX NEWS

22

10MHz / 1MHz calibrator

11

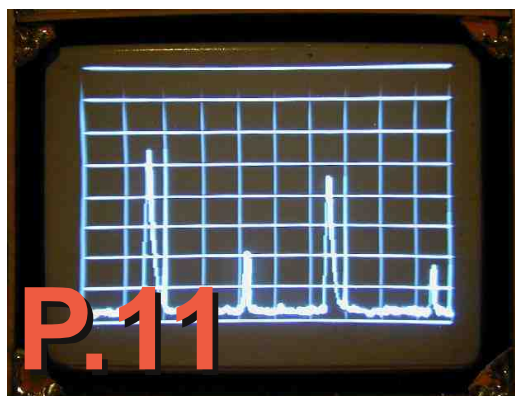



POST-IT !

The breaking News



Iceland Amateurs Receive New Privileges

As of Friday, February 19, Iceland's Post and Telecom Administration (PTA) granted temporary experimental access to the 4 and 600 meter bands at least through the end of 2010, according to Islenzkir Radioamatorar (IRA) President Jonas Bjarnason, TF2JB; the ITA is Iceland's IARU Member-Society. After obtaining a special license from the PTA, Bjarnason said that TF stations with "N" or "G" class licenses may now operate between 493-510 kHz and 70.000-70.200 MHz running 100 W. Amateur operations on both bands are granted on a secondary basis.

Launch of New ARRL Web Site Delayed to "Get it Right"

After meeting with ARRL staff on February 23 -- two days before the new ARRL Web site was to launch -- ARRL Chief Operating Officer Harold Kramer, WJ1B, made the decision to delay the unveiling of the Web site until late March. "Work on the new ARRL Web site has progressed at a frantic pace but there are still some potential 'bugs' that could affect members. We need to be sure we get it right," Kramer said. "Our members' security, information and ability to actually use of all the options on the new site outweigh any rush to meet an artificial deadline. It's just good customer service."

The new Web site -- which will contain the online store, class registrations, audio, video, DXCC information, contest data, individualized member options and other 21st century opportunities for members -- is one of the largest technology upgrade activities that ARRL and Fathom, the company programming the site, have ever undertaken. "Reviewers have been unanimously impressed and are helping make sure we create the easiest, most enjoyable online experience possible," Kramer explained. According to ARRL Media and Public Relations Manager Allen Pitts, W1AGP, the current ARRL Web site is not only used by ARRL members, but is a prime reference source for engineers, hams and wireless technicians around the world, making it the premier place to find information about Amateur Radio, its activities and the sciences behind it. "The Web is our main face to the world, and the new Web site will be fantastic," he said. "Although we all regret the delay, I believe our members will appreciate our diligence about the ease of use, security and navigation for the new site."

Tweets in space - ISS gets web access

In a high tech first, astronauts in space finally have Internet access.

Space station resident Timothy Creamer has been working with flight controllers to establish internet access from his orbital post ever since he moved in last month. He posted the first live tweet truly from space. "Hello Twitterverse!" he wrote. Before, astronauts had to send Twitter updates by e-mail to Mission Control in Houston. Then controllers posted the tweets. The International Space Station crew can now use an on-board laptop to see a desktop computer at Mission Control, and thereby browse the web. This remote internet access is possible whenever there is a solid high-speed communication.

**Win a... One year active member of Ham-Mag.
Send us an article and when it is published you win your adhesion.
Tell it to your friends.
Send article to : f5sld@free.fr**

Continuous feed source of 14V0-68

By YO6QCZ

The confection idea of this source came from the feeding necessity of some devices (like: clock , economic light bulb at 12 V , radio stations) because of the lack of electric stream, on a definite limited time period (depends on the battery capacity).

I've chosen the usage of a slug (Pb) battery with 12V - 7 Ah tight acid (used in a lot of industrial schemes, like : alarms, opening door latches, etc).

I've thought for a scheme with the automatic charge possibility of the battery from the 220V network by the instrumentality of a redressor-transformer and of a 555 tip circuit with the possibility of tuning the charging lintels (up) and (down) with the help of some semi-adjustable.

The charging I is given by the R4 resistance, which is around the value of 0,2 A. The pieces are mounted on a lay with the exception of the transformer, of the fuse on the battery and of the LED diodes which signalls the state of device.

Diode (LED1) signalls that the device is conectet to the 220V network.

Diode (LED2) signalls the voltage presence to the vent + 13V

Diode (LED3) signalls that the battery is charging ; This diode turns on and off automatically at an interval of approximate 30 seconds - based on the voltage tunings - the upper lintel and the lower lintel - of the semi-adjustables. The scheme is functioning from the start, but the two lintel semi-adjustable must be adjusted.

Stuffs list

TR 1 - 220/15V - 1 A

P1 = B100C1500R

Z1 - DZ10V

T1 - BC171C

T2 - BD238

C.I. - NE555

S1,S2 - semi-adjustable 0,5W - 10K

Sig 1 - 1A

Sig 2 - 4A

R1 - 330Ω 10,5 W

R2 - 1K 10,5W

R3 - 330Ω 10,5W

R4 - 24Ω 2W

R5 - 6K - 0,5W

R6 - 18K - 0,5 W

R7 - 220 Ω

R8 - 1K Ω

R9 - 2 K2

Accum = 12V / 7 Ah

S1 - it adjusts for U max = 14,2 V

S2 - it adjusts for U min = 13,4 V



Once made this two adjustments, the device is functional .

I wish you : Success !

YO6QCZ - Dorin

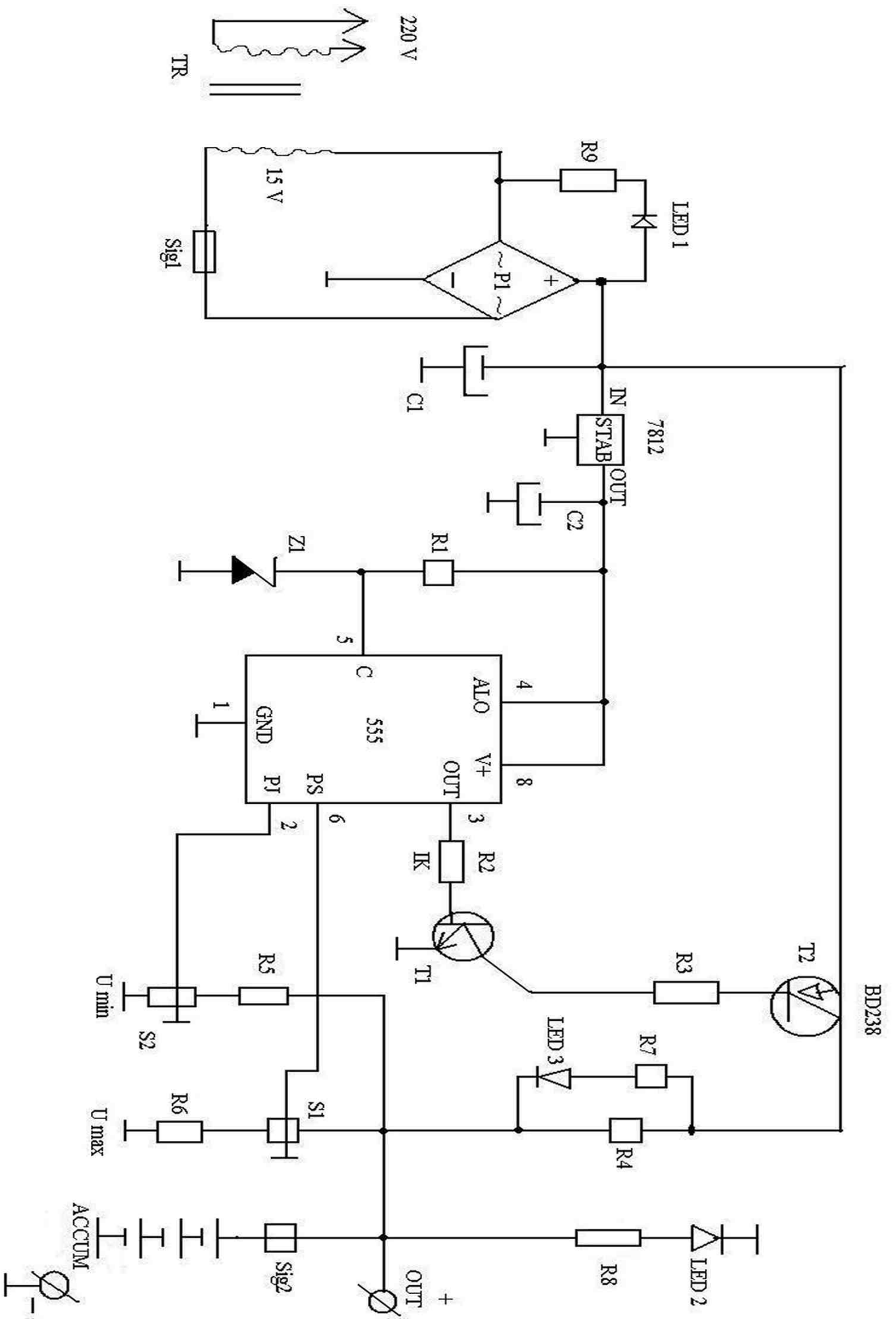

Coaxial cable continuity tester by John R L Walker ZL3IB



If you are like me you probably have a number of coaxial or shielded cables terminated with a wide range of plugs in your shack. Testing these for shorts or open circuits is made even easier with this ultra-simple project. The original

circuit was devised by S. Roberts and first appeared in Electronics World, March 1996 but I have modified it to also indicate short circuits.

How it works.

Green LED1 lights for inner conductor continuity and green LED2 checks the outer shield. If there is a short circuit neither green LED is illuminated since they are both across the cable and increased current flows through the current limiting resistor R1. Consequently the voltage across R1 increases and when this exceeds a threshold voltage set by the Zener diode ZD the red LED3 lights up to indicate a short circuit. The value of R2 may need "tweaking" slightly to compensate for variations in the Zener voltage of ZD.

Constructional notes. Builders may include as many different pairs of sockets as they require. In my case I have included SO-239, BNC, Belling-Lee (for TV antenna cables), RCA phono, miniature and standard phone sockets.

Remember, all the sockets must be isolated so it makes construction easier if you use a non-conducting material for the front panel.

Parts List

LED1, 2 green
LED3 red
R1, R2* 470 ohms, ¼W
ZD 5V Zener diode
Socket pairs as required

*Exact value may need "tweaking"; see text
(This article was first published in Break-In

73's ZL3IB

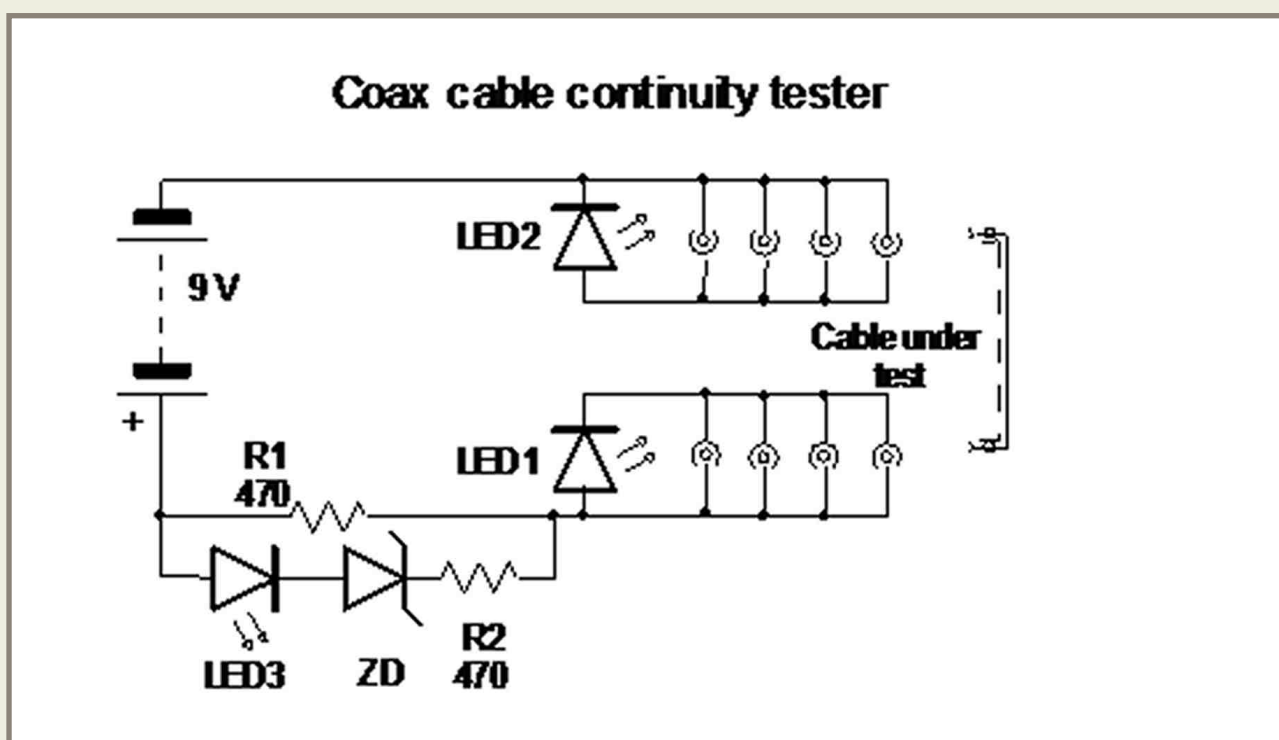

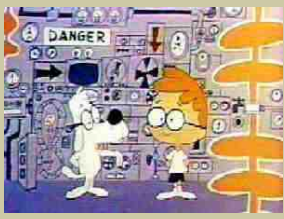

The Venerable VTVM by N4PRT, Patrick

Alright Sherman, it's time to join Mr. Peabody and "Set the Wayback Machine" for 1970. We have arrived in an average sized Midwestern town where we will visit two electronics operations—one a television repair shop and the other a ham radio shack. Observe closely, for we are looking for something very useful that can be brought forward to today's shack workbench.

Remember that these are still the days of the vacuum tube—solid state is becoming more common in home entertainment applications, but for the ham much of his or her radio equipment is still firmly based on "hollow state" devices. In both the TV shop and the shack, there is one piece of equipment that holds a position of prominence at the front of the bench—the vacuum tube volt meter, or VTVM.

An RCA Senior Volt-Ohmyst holds court at the TV shop, while a Heathkit IM-18 built by the amateur presides in the shack. While these two meters look quite different in shape, the surprise is that they have essentially the same circuit inside. In fact, the VTVM has changed little in its design since it was first introduced in 1916.

Having identified our historic prize, we move forward to the present time and examine what a VTVM can do for us today. After all, are not our modern digital (DMM) and analog (VOM) multimeters much more accurate and versatile? As we will discover there are many things that one can accomplish with a VTVM that simply cannot be done reliably or with the same degree or responsiveness as with more modern equipment.

The first task of course is to get one of these handy instruments into our possession. A quick way to find anything is to check eBay. A search of completed auctions reveals that a number of different brands and models can be had ranging from \$10-50 in price, with \$25 the average cost. Other sources can be hams that are not using these anymore, estate sales, and hamfests. Make sure that the meter you are considering has its probes, powers on, and preferably has a manual.

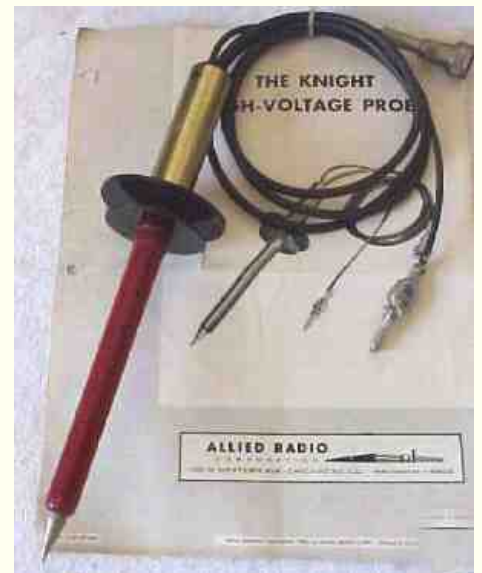

Quite a few brands are available. A short list of the most common include RCA, B&K, Knight, Heathkit, Eico, HP, Simpson, Triplett, and others. Test equipment manufacturers frequently offered several kinds of accessory probes to round out the capabilities of the VTVM—very similar to those found for oscilloscopes. These included high voltage, RF voltage, demodulator, and even specialty probes for temperature and pH. Due to the universal design of many VTVM's, these probes will often work across brands and models.

Older VTVM's produced prior to the 1960s lack two important features. First, they do not measure resistance—scales only reflect voltages and decibels.

Second, in the early 1960s a 1.5 volt scale was added to improve accuracy when measuring smaller voltages (even a .5 volt scale in some cases). A few models of older VTVM such as the Hewlett Packard 400 series actually had a vacuum tube in the probe itself. Another limitation is that the test leads were usually an integral part of the unit—hardwired to the circuitry and not interchangeable. While these meters can be made fully functional for today's bench, it is recommended that a more recent and versatile vintage be selected.

Now that we have a VTVM on the bench, the real question becomes what can we do with it that our DMM or analog VOM is not capable of? To answer this question let's first look at how the VTVM works. In a nutshell, the VTVM uses a dual triode tube (usually a 12AU7) in a balanced bridge circuit to amplify incoming voltages. This sort of design provides several useful functions. A diagram detailing the most common VTVM circuitry is shown at the end of this article (RCA WV-98A).

The first is that a very high impedance (approximately 10 M Ω) is shown to the circuit under test. This provides a high degree of isolation between the metering circuit and the test circuit—resulting in a very low “load” placed into the tested circuit. Such a configuration is very convenient in low power, coupling, amplifier, and resonant circuits as it does not change the operational characteristics of the circuit. This characteristic is shared by many quality digital meters.



A high degree of amplification in the metering circuit also means that very high resistances up to 1000 M Ω can be measured. This is useful in determining dielectric resistance, leakage of capacitors, transmission line characteristics, and isolation leakage. The amplification factor is also beneficial when measuring small audio or IF voltages, giving one a true indication of the performance of the circuit under test.

A unique ability that a VTVM has that a DMM or VOM does not is to read AC voltages in both RMS (root-mean-square) and P-P (peak-to-peak) values. The common DMM/VOM averages the AC sine wave and delivers an RMS approximation of the voltage. By using P-P voltage measurement, more complex sine waves and other waveforms can be accurately measured—the added benefit being that the P-P measurement coincides with how an oscilloscope measures voltage. Combining the VTVM with a scope delivers waveform observation that shares the same measurement standard.

The measurement of complex sine patterns or other forms such as square or sawtooth is best accomplished with the VTVM. In situations where there are likely to be rapid variances and transient spikes present in the signal, the VTVM shines with its rapid response and ability to correctly decipher the correct voltages at hand. This instrument is also relatively immune to false indications due to interference and strong electromagnetic fields. It is also much easier to determine the minimum and maximum changes in a circuit by following the meter needle than trying to make sense of a wandering digital display. This alone eases any receiver alignment process.



Here are a few of the better uses of your VTVM:

- Measuring coupling and other capacitor leakage
- Troubleshooting audio circuits
- Measuring voltages in tuned and resonant circuits
- Determining reactance and inductance of components
- Alignment of tuned circuits
- Measurement of potential 1500 V and above (with proper probe)
- Direct measurement of high frequency voltages
- Ability to measure DC in the presence of AC voltages

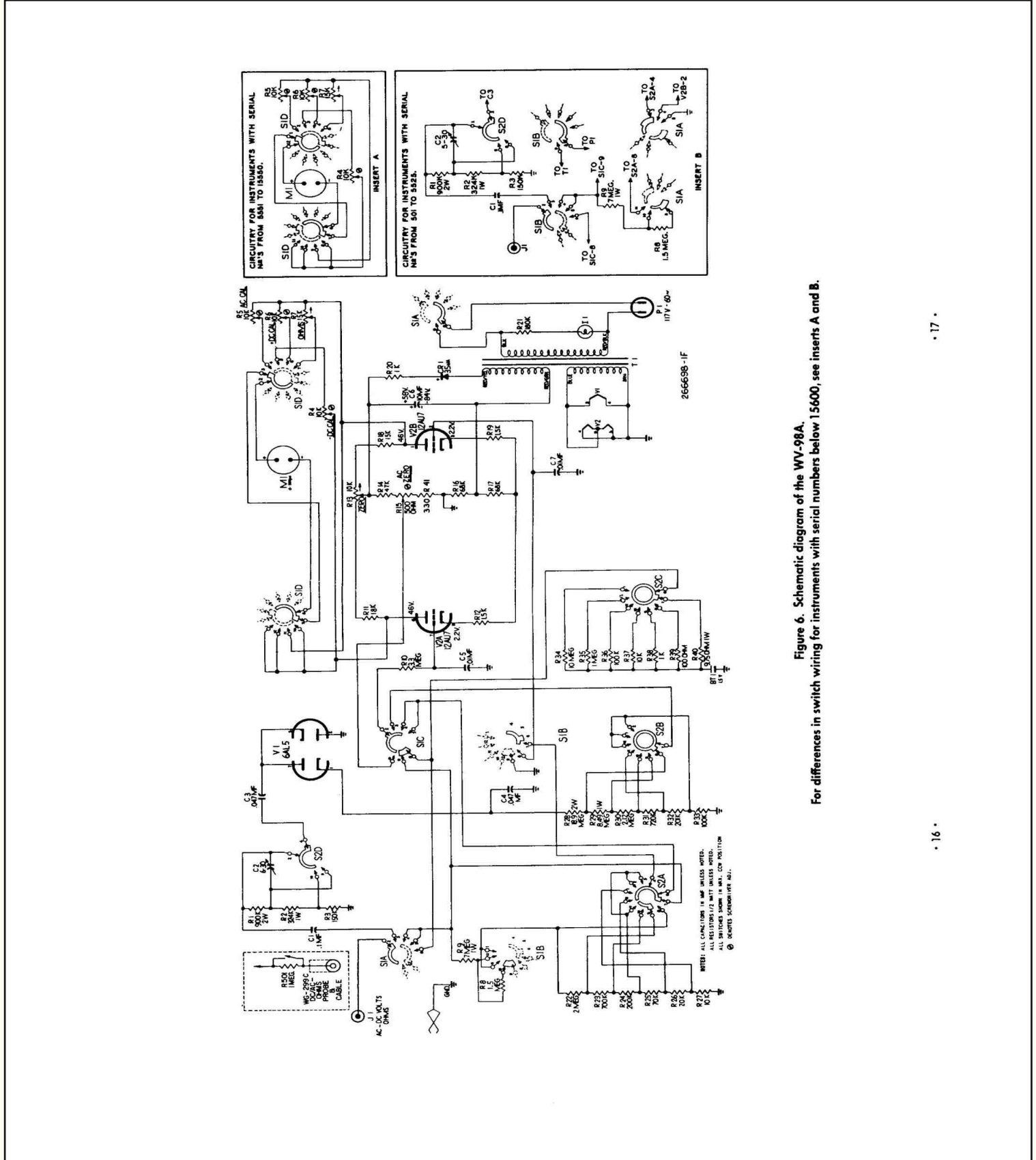

Figure 6. Schematic diagram of the WV-98A. For differences in switch wiring for instruments with serial numbers below 15600, see inserts A and B.

As might be expected with any older test equipment, your “new” VTVM will likely need a little care before it can serve reliably on your bench. All paper based capacitors over time will become leaky—and require replacement. Depending upon the age of your unit it may be wise to simply replace the coupling and any electrolytic capacitors that may be present in the circuit.

Rotary control switches and adjustable potentiometers become dirty through oxidation and contamination. These should be cleaned with a quality solution such as a spray on cleaner/lubricant or an application of a solution such as DeoxIT. This applies to calibration trimmers as well—a thorough cleaning and recalibration as given in the instruction manual is recommended.

Interestingly, quite a few VTVM’s used a battery to supply the resistance measurement voltage. A first check of the interior of the meter will look at replacing this battery and repairing any damage done by leakage of an old cell. Some enterprising technicians have tapped into the tube filament voltage to feed a circuit that provides a stable 1.5 volt DC supply—thus eliminating the need for a battery.

Once the dominant instrument in any electronics shop, the venerable VTVM still has a valuable place on the radio amateur’s bench. VTVM Sidebar Resources

Although it has been many years since the majority of VTVM’s were made, a wealth of resource material is still available to the bench technician and hobbyist. A quick search of Amazon.com turned up nearly 20 unique used books detailing meter operation and a variety of troubleshooting techniques.

The most complete reference for these meters is “The VTVM” by Rhys Samuel. Originally published in the mid-1950s, copies in hard and soft cover are still available at a reasonable price. As noted, it is important to have a manual for your VTVM. If one did not come with your meter, a number of online resources exist that will provide you with one.

Here is a list of a resources for the new VTVM user:

Books

101 Ways To Use Your VOM and VTVM
Robert G. Middleton, 1959

Troubleshooting With The VOM and VTVM
Robert G. Middleton, 1962.

Know Your VOM-VTVM
Joseph A. Risse, 1963.

The VOM-VTVM Handbook
Joseph A. Risse, 1972.

On The Web

BAMA Manuals & Schematics
<http://bama.sbc.edu/index.htm>

73 from N4PRT

10MHz/1MHz Calibrator/ Marker generator.

By John R L Walker ZL3IB



A simple frequency standard can be a useful accessory in the ham shack. Similarly the ability to include some sort of frequency marker into a spectrum analyser displayed is very helpful and this can be done using an external signal source. However an internal marker is handy so I constructed a very simple 10MHz/1MHz marker generator. This used a 10 MHz crystal salvaged from an old computer and in my unit produces a 'comb' of peaks on my spectrum analyser to over 350 MHz.

Fig below. Marker generator
(This article was first published in Break-In July/Aug 2002)

73 ! ZL3IB

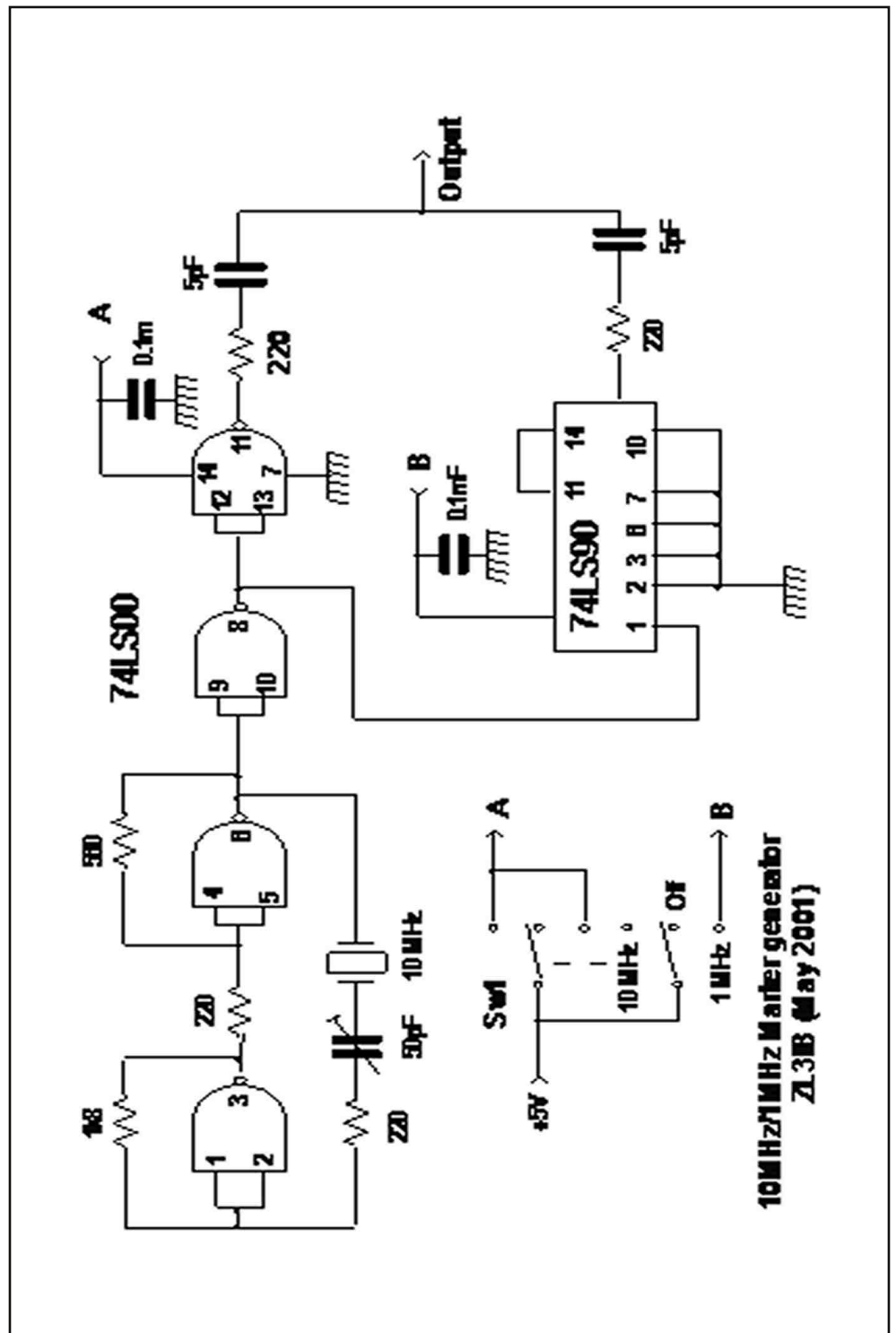

YO2BS - 50 YEARS ON THE AIR

op. Aurel Sahleanu QTH : Timisoara ROMANIA



I Was born 73 years ago in the city of Timisoara, almost a half million inhabitants, which is the second large city in Romania after Bucharest, the capital city.

In the ancient times this territory was populated by Trac tribes (from the Greek branch), which were defeated by the Romans in the year 101-106 a.C. and so they became a part of the Roman Empire during almost 200 years in the beginning of the new era after Christ.

So, the Romanian language is very similar to the other Latin roots languages and for us is very easy to understand Italian, Spanish, French and Portuguese.

The history of our town begins 750 years before, when there has been built a military stronghold, which ruins can be seen till to day in the middle of the city. The first written document found from this period was from mid of the 13th century.

In the 16-17 century the ancient city was under the Turkey's government and then in the 18-19 century under the dual Austrian-Hungary Empire. In the beginning of the 20th century, after the first World War, the region of Transylvania (in the center of the country) and the Banat county, (in the extremely western corner of Romania) which capital city is Timisoara became a part of Romania, being populated in majority by Romanians.

At the present time Timisoara is a big university and industrial city, with a Sciences University, a famous Technical University and a well known Medical University, with all about 150 000 students. There are also many factories, in special electrical, chemistry and construction companies. We have many parks, hotels, restaurants, an opera-house, a philharmonic, three theaters, a nice football and athletics stadium, a big orthodox cathedral, and much more others.

Now about me :



My profession is electro-engineer, retired now for 10 years. I was working 40 years in the field of electronics, among them 25 years as chief of the Technical Department of the Romanian Radio and Television Broadcasting Corporation, Directorate for the West of the country with the base in Timisoara. I am married with a charming lady which is my wife and we have two sons, both of them electro-engineers, but no one likes to become a HAM. The oldest, emigrated in Canada works for an electronic company in Toronto, and the youngest which emigrated in Germany works by the Siemens Company in Ludwigshafen.

Do have a pretty niece from my oldest son and a lovely nephew from the youngest son. Maybe they would like to become HAMs, who knows...

My only hobby is amateur radio, and especially DX-hunting on the VHF bands. Don't like contests and UHF work...HI



I discovered the world of radio when I was a 15 years old schoolboy. It was a very interesting event which marked my entire life and also my career :

A day, I think it was in the autumn of 1952, I took the old tube-radio receiver of my family to a repair shop. The radio was out of order next I opened it to see what is inside. After that operation the radio makes a big noise when tuning, and noting else to hear...

The old man in the shop took a shaving-blade and fix the problem immediately, resetting the distance between the plates of the variable capacitor. When I

asked him how much cost the repair, the old man says : " Nothing ". Then looked at me asked if I would like to help him repairing radios, and he will learn me all about radio-repair. I was astonished and replied him that I am a schoolboy and I must go at school everyday. He says : "Nevermind, you shall come after school, in the afternoon" . After a short thinking I agree, and so I get an apprentice in radio-repair, during the next two years.

I heard from amateur radio as I graduated from the highschool and get a student in the first study year of the Technical University of Timisoara, in the autumn of 1954 year.

Once I saw in downtown a panel with beautiful color QSL cards from all over the world, which impressed me very much (and that's the reason I love collecting QSL-cards till to day), and an invitation for youth to participate to an exhibition of the radio-amateurs.

There were some exponents of radio-equipments built by the radio-amateurs, and also a radio-station which makes some demonstrative QSOs. I was very excited and I decided to become a HAM. So I registered myself to the courses for beginners, by the County Radioclub and get instructed in Morse code, radio-traffic, get some notions of radiotechnique Q-code and English language. So, in 1955 I become a SWL with the call sign YO2-215. I was a very enthusiast SWL during the next two years, collected QSL-cards from more than 100 countries, and got some SWL awards like DXCC, HAC, HAE and others.

In 1957 I become an operator by the County Radioclub station YO2KAB and in 1959 after passing the third class examination I got my personal call sign YO2BS as a novice operator, and begun working CW on 3,5 and 7 MHz, with a homebrew receiver and 25 W transmitter. In 1961 after a hard examination in Bucharest I got the first class license (for all HF bands, 400 W input). In those times in Romania where nothing to buy from radio transmitters or short-wave receivers. Having the skill and the necessary knowledges I started to built myself the radio-equipment I needed for the hobby. So I built some tubes radio-receivers and transmitters and started working in CW and AM-Phone with 300 W. After apparition of SSB-mode, in 1968 I built an 100 W SSB transmitter and than in 1970 a SSB 5 band 100 W transceiver , a 400 W linear amplifier, and a 2 element cubical quad antenna, and started working very intensive in SSB, been between the first 5 SSB-users in our town. Being more and more busy with my professional activity, and don't found any more the necessary time for my hobby radio-construction, I had the opportunity and bought myself in 1975 an HW 101 from Heathkit (a 100 W SSB transceiver in kit), which I assembled myself in my free time. With this nice equipment I begun effectively the DX hunting. The outstanding propagation in those years, helps me to make beautiful DX-QSOs reaching over 300 countries in CW and SSB and getting also over 50 HAM-awards.



In 1995 I bought a FT 890 AT transceiver from Yaesu and started working in digimodes and in 2000 a Kenwood TS 850 SAT ,a beautiful radio,which I use also in present time. I kept also my old equipments and use the HW 101 for SSTV and RTTY mode,the FT-890 AT for PSK and OLIVIA mode and the TS 850 SAT with the Linar Amplifier 400W for CW and SSB mode. Antennas I used : the 2 element 3 bander Cubical-Quad is now damaged after a big storm,have a 20-15-10 m GP antenna for the classic bands and another 30-17-12 m GP for the WARC bands on the top of the tower-buiding I live

For the lower frequencies I have a Windom antenna which I use for the 40 and 80 m bands and a shorted dipole (with end coils) for 160 m which are installed between my location and another high building.

At the present time I do have confirmed 327 countries (mixed) on the HF bands and look for to carry out the 9 band DXCC (need only 15 more countries on 160 m band).

In our town we had about 20 big DX-men from my generation. Between them I mention the : YO2BA (SK), YO2BB , YO2BC (SK) , YO2BD (now DL9FCD), YO2BI (SK), YO2BL (now DL4VAQ) , YO2BM , YO2BN (SK), YO2BO (now WB2AQC) ,YO2BP , YO2BQ (SK), YO2BS (my self), YO2BU (SK) and YO2BW (SK) .



Today there are more than 30 another young HAMS (with 3 letters at the suffix) which operate especially in digi-modes and also phone on UHF. Unfortunately the new generation of radio amateurs don't know the Morse code (which is not needed any more to get a HAM license),and they could not be able to work in CW which is a big handicap getting a great DX-man,most of the rare DXs (DXpeditions in exotic Islands on antipodes) works only in CW. That's the reason I think the era of the great DX-ers is setting down now. A new communications era rise's and may be one day the most common DX-QSO will be on Digital-TV trough satellites. Will see...

Your friendly Aurel Sahleanu YO2BS.



Nr. T/33/99-A

1 Numele / Name / Infabers: SAHLEANU
 Prenumele / First Name / Prenom: AUREL MIHAI

2 Data și locul nașterii - Date and place of birth - Date et lieu de naissance - Geburtsdatum: 18.08.1937, TIMISOARA, JUD. TM

3 Domiciliul - Place of residence - Domicile - Wohnort: TIMISOARA, STR. MENDELEEV NR. 6, BL. T6, ET. 2, AP. 12, JUD. TM

4 Amplasamentul stației - Location - Emplacement - Location: TIMISOARA, STR. MENDELEEV NR. 6, BL. T6, ET. 2, AP. 12, JUD. TM

5 Clasa - Class - Classe - Klasse / CEPT Class - Class - Classe - Klasse: I I

6 Indicativ de apel - Call sign - Indicatif d'apel - Rufzeichen: YO2BS

Director general, SUMA CLAUDIU



80 - 40 Wire antenna

By Chris Wright VK2UW

I designed this antenna to suit a small yard where Hams are restricted to either only vertical antennas or trapped antennas.

This way you can use a full 1/2 wave Dipole on both 80 / 40 mts and by doing the same if needed for other bands including 160 / 80 mts etc even down to 15 / 10 mts, you can also lengthen the fibreglass rod so as to make a Fan Dipole to include other bands if needed.

If your yard is smaller again you can lengthen the fibreglass rod so as to shorten the over all length even more.

Feeding the antenna is entirely up to the operator as you can feed it direct or with a 1 to 1 balun. Make the centre point a minimum of 6 mts and drop the ends down to at least 3.5 mts from the ground.

The antenna is easy to tune as all you have to do is let the end guy ropes loose and alter the length of the wire element on each side of the insulator, set the 80 mt one up first : if SWR is lower higher up in the band then just lengthen the wire dipole and the same goes for 40 mts as well.

The heavier the wire preferably a multi strand wire like earth cable is suitable and will give a better band width and low SWR over that range.

I do not use an ATU on this antenna even using my QRO Emtron Amplifier both on 80 and 40 mts.

Power rating depends on how you feed the antenna and the rating of the balun and guage of wire, I usually wind my own baluns by either using Tri-ifular type baluns or a Heavy duty Toroid type with Tri-ifular windings. If using a PVC pipe and Tri-ifular windings it depends on the size of the PVC that you use to wind the windings on as to the power handling and also the wire size come into it as well.

I purchased the fibreglass rod that is used on electric fences and instead of using eye bolts as shown I used PVC pipe and cut it 75mm or 3 inches long and drilled holes 1/2 inch or 12.5mm in from each end and slid these down the fibreglass rods 1 inch or 25mm from each end and drilled a 1/8 hole through the fibreglass just above the PVC pipe and tied a wire through this and down under the PVC pipe and wrapped it round the fibreglass rod so as to stop the insulators sliding together and maintaining the spread at the fibreglass rods.

I also used the same PVC pipe and hole setup for the Insulator where the 80 / 40 mt dipoles are terminated on the lower side of the antenna. These measurements will change due to location / ground factor and how you mount the antenna. The measurements are a guide as this is what the one that I use is set at.

You can use this setup as an inverted "V" or straight dipole steup or even in a "L" shape in the back corner of your yard if needed. You can make up many different types this way for different bands especially for DXpeditions and the like or for travelling.

I also found by just changing the length of the original antenna you can tune in many other bands, so by marking the ends on one or the other of the 80 / 40 dipoles you can have it setup where you want to use it most, and also eliminate the use of an ATU in line.

(Pictures on the next page)

73's de Chris Wright VK2UW

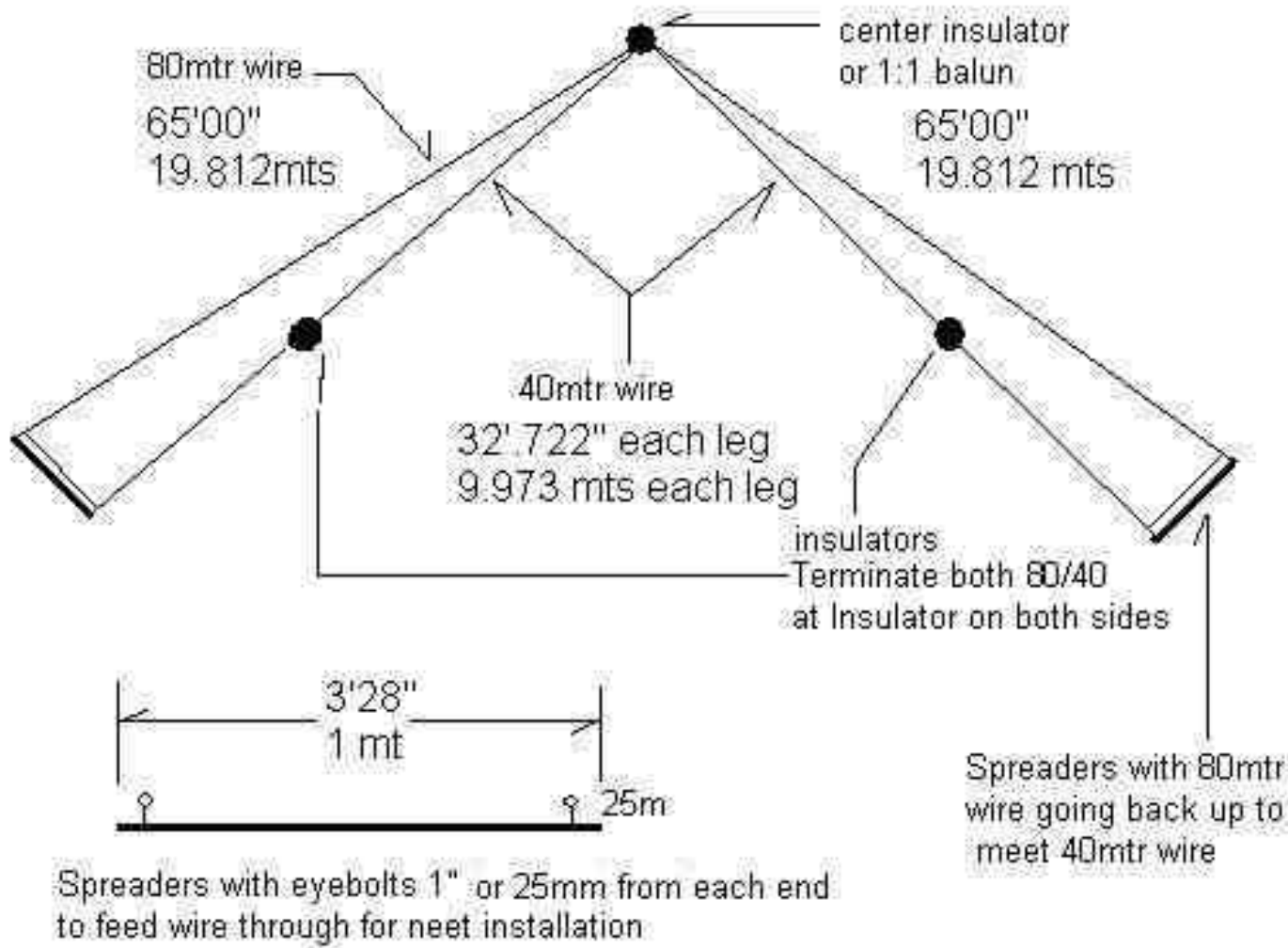
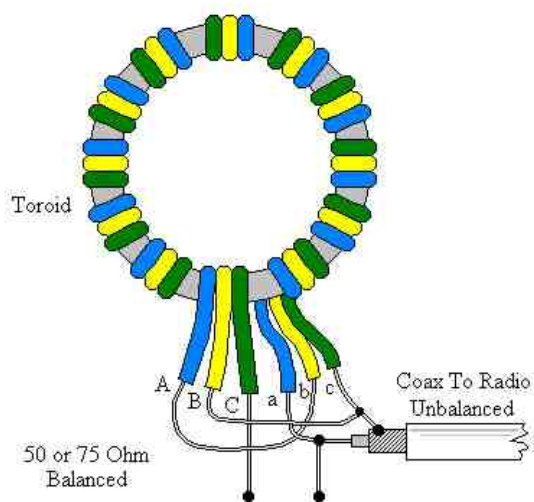

Figure 3 1:1 Balun Transformer



MFJ-269 Review

By VK2ZAY, Alan



After my review of my MFJ-207 Peter VK2TPM offered me his MFJ-269 to play with for comparison. Naturally I jumped at the chance. The MFJ-269 is the fully-featured descendent of the earlier and simpler antenna bridges like the MFJ-207. The manual can be found on MFJ's website.

The device is microprocessor based with an LCD interface and two main control buttons "Gate" and "Mode". There is also a Frequency band switch, a reduction geared tuning capacitor, power and UHF mode switches. Two analogue meters display SWR and impedance magnitude continuously, offering a trending display which is more user-friendly than the figures on the LCD display. In UHF mode there is a "bargraph" of sorts on the 2nd line of the LCD for trending SWR.



The unit tunes about 1.76 MHz to 172.7 MHz in six overlapping bands. There is also a "UHF" switch that triples the oscillator in the 114-170 band giving 415-470 MHz coverage the edges of which are enforced in software, the display telling you to increase or decrease frequency until within that band. UHF supports only loss and SWR features, not reactive measurements - likely because bridge performance issues at UHF would have required extensive calibrations to have any hope of accuracy.

The coaxial connector is a N-type and is surrounded by a generous rubber gasket. The frequency counter input is a BNC. The DC plug is a conventional unit, tip positive, I am unsure what internal over-voltage and polarity protection it has. There is a large grounding lug also provided.

Features

There are 4 "Main" analysis features and 3 additional menus of Advanced ones. The advanced ones are mostly just different presentations of the same data from the bridge voltages (impedance in polar form, reflection coefficient, return loss, etc), but there is the option to select a different "Zo" for the calculations and also a two-frequency point semi-automatic calculating feature for line length, distance to fault, etc. The line length and fault distance calculations are pretty good, resolving several short (~2 metre) lines and offering compensation for velocity factor.

By pressing the "Mode" button you can cycle through the different modes, both main and advanced (once entered). Holding both the "Mode" and "Gate" buttons gives access to the advanced menus. The "Gate" button is used in frequency counting mode and as an enter-key of sorts in the calculating modes. Holding both buttons down on startup then alternatively pressing them as it boots enters the "Test" mode which gives a display of the raw ADC data for calibration of the unit with a set of calibrated dummy loads. The button mashing required to enter "Test" takes some practice, thankfully it isn't something you'd be doing often. The software version is displayed at boot, in this case 4.46, copyright 2004.

Impedance Analysis

The default "main" mode is the "Impedance R + X" mode and displays frequency, VSWR, and impedance as Resistive and Reactive magnitude (Rs +/- jXs) which update continuously as you tune around. The sign of the reactance is not resolved and displayed, which is pretty typical of the bridge system the device uses. The frequency counting is probably the "killer feature" of the device as well as the reactive magnitude display which allows searching for true resonances not just minimum reflection coefficient magnitude.

The impedance mode does seem to work pretty well, especially below 50 MHz, but is limited by the device's calibration accuracy. I am not very confident the unit I was playing with is calibrated properly, resistive magnitudes reads high, sometimes more than double - and above 300 Ohms resistive the reactive magnitude rises very quickly too, even with a "pure" resistance in the lowest frequency band. This and other behaviour I noticed suggests the "Vz" channel gain is a bit high. Upon checking the calibration pots under the battery holder I noticed that R72 was bottomed out, offering insufficient range to properly calibrate the unit as described in the calibration procedure. This is suggestive of mismatched or damaged diodes in the bridge or perhaps an incorrect resistor value or tolerance catastrophe. As the unit is not mine I didn't pull it apart to inspect the rest of the circuit and attempt to diagnose it further.



Coax Loss

The second "main" mode is "Coax Loss". It appears to simply display half the return loss measured by the bridge. When an unterminated coax line is attached the bridge sees the through-and-back (returned) loss of the line, which is twice the line loss for that particular length. Similarly you can attach attenuators and other lossy devices to the unit and measure their loss this way. The loss maximum appears to be 24 dB and is likely limited by the best bridge directivity over its frequency range (ie 48 dB, pretty good). As the unit is measuring with a 12 bit ADC a linear signal (not a log detected one) the dynamic range is pretty limited and the loss quantisation is fairly coarse. For "good" vrs "completely waterlogged" measurements of coax it is likely sufficient.

One annoying thing is the lack of auto-zeroing, this particular unit would always read about 0.9 - 1.6 dB return loss at HF. It would be nice to have software zeroing. In fact I can't see why the entire device could not have been designed to ship with a set of calibration loads and full software fine calibration. I do understand that some of the gain settings are quite critical, especially for reactance zeroing with the limited dynamic range offered by the 12 bit DACs fed by linear detectors. Still it would be nice to have "tare"-style zeroing for some measurements.

Capacitance and Inductance Measurement

The Capacitance and Inductance measurements simply compute the reactor value that matches the current reactive magnitude reading at the current frequency. It has no way of telling if the load is actually inductive or capacitive, and once outside the few ohms to 1.5 kohm range of reactance magnitude the software stops giving you a solution. This makes perfect sense, you just need to tune the VFO until the frequency offers a reactive magnitude in-range of the unit. The computed values are most accurate when the reactance magnitude is close to the bridge reference resistance (50 Ohms). This particular unit read high, about 19 pF high (about 6 pF of which was the test fixture) on average and again there is no way to null it.

Inductance was probably worse but I didn't test it extensively, only a few trial inductances were compared to values measured by my LC tester. The LC measurement is nice to have, but I wouldn't trust it - in fact I'd go as far as to suggest using the frequency counter feature along with an external jig like the LC tester instead.

Correctly calibrated the general measurement method is probably fine and quite useful as it tells you the true impedance of the reactive component at radio frequencies (unfortunately only those that present a 7-1500 Ohm impedance). For testing a component for spurious resonances this is very useful, but in practice I couldn't seem to easily find misbehaviour in capacitors. Inductors on the other hand were fairly easily tested for self resonance, but being placed in the tester environment pulled their self-resonances quite a lot. Dipping them instead is probably more reliable.



Frequency Counting



The frequency counting feature works as advertised. It can accept signals up to 5 volts and has a high-impedance input. I could easily get a stable measurement with just a few turn coil plugged into the input using my dip meter as a signal source from several inches. The counter counts to beyond 170 MHz, I didn't test it higher. I assume the "UHF" feature actually counts the VHF generator and triples the value in software? I can't see a counting range spec in the manual. The gating works as expected, long gating times give more resolution figures. The reference seems stable and accurate enough for the resolution offered.

Advanced Features

Of the "Advanced" modes the stub length and resonance searching ones are probably the most useful. The stub length helpers are great for cutting matching and phasing stubs. Accuracy for 1/4 lines seems pretty good when compared to dipping a line with other instruments. It is unfortunate that the physical lengths are only given in feet. A metric physical measures software option would be nice, but considering this is a US product this is perhaps not surprising. The resonance searching mode makes the Impedance magnitude meter show Reactive magnitude while looking for a null. Oddly it does not use the LCD bargraph like SWR in UHF mode, instead showing Xs numerically.

The match efficiency mode is arguably the most useless feature. I'm not really sure what the point of it is. I guess there was extra room left in the MCU code space, so yet another "feature" was invented to fill it. Personally I'd prefer metric measures or software nulling instead.

Use as a Dipper

I understand there is an optional dipper coil set for the MFJ-269? - I just plugged my few turns of wire on a BNC into it and tried it out on some inductor self-resonances. It works quite well on HF and VHF. I'm not too confident about it on UHF, but the UHF range is quite narrow which makes it fairly useless for dipping anyway.



Power Consumption

The device does guzzle power. On HF-VHF in the default mode it pulls 140-170 mA (rising with frequency). On UHF it pulls over 350 mA! In counter-only mode it still pulls 90 mA. The AA batteries won't last long, and it takes 10 of them. Unlike the MFJ-207 at least you only need to remove two short machine-threaded screws to access the batteries.

The external power option is almost mandatory (use at least a 500 mA plug-pack), but it does offer the ability to charge rechargeable batteries inside the unit by changing a jumper on the PCB. I have no idea how well it manages them if you choose this option.



By default the unit enters a sleep mode to reduce power consumption after a period of inactivity. This would help extend battery life, but it still pulls more than 50 mA. The sleeping feature can also be disabled by holding down buttons while the unit is powered on and remains disabled until the power is cycled again, much like Test mode.

Comparisons to the MFJ-207

The 207 is very basic compared to the 269. The 269's frequency counting and reactive magnitude display are its best features. The 269 has none of the FMed oscillator problems of my particular 207 and has much improved buffering and harmonic distortion. There is a pot in the 269 for setting buffer bias up to minimise the harmonic energy. I didn't test it extensively, but there is a detailed procedure available using a coax stub instead of a spectrum analyser to ensure this is set correctly.

Tests with narrow band antennas like my balcony HF vertical and bicycle loop antenna show it is very much improved over the 207. I can resolve the resonance of my balcony vertical on 80 metres with the 269 fairly easily where it is next to impossible with the 207.

I even tried measuring a colourburst crystal with the 269. The xtal resonance is very steep and the analyser tries its best, but it is simply not sufficiently stable or well buffered enough to stay in the resonance. You can detect it and even get a fairly good idea of its frequency however, and see spurious resonances of the xtal as well.

The 269 covers part of VHF where the 207 stops just above 30 MHz - and the 269 also has the narrow UHF option. On UHF the 269 is essentially as limited as the 207 is on HF, measuring just return loss. I am highly suspicious of the UHF feature's accuracy and debate its actual usefulness for most HAMs. Like the 207 the 269's SWR meter is largely just for trending.

The calibration point is 2:1 (using a 100 Ohm load), above and below this the displayed figure is quite wrong. The LCD display however shows the correct figure, at least below about 5 - and of course if the unit is calibrated properly. (The impedance meter is a bit better, its calibration point is 50 Ohms using a flat load. Again the screen gives a more accurate reading.)



Summary

The good:

- Frequency display
- Reactance magnitude display
- Separate impedance and SWR analogue meters
- Mechanical reduction driven tuning capacitor
- Display options including RL and P
- Fairly compact unit, self contained
- Reasonable accuracy (if properly calibrated)
- Fairly stable and pure local oscillator
- Internal battery charging option

The bad:

- Large power consumption
- No nulling options (especially for L/C measurement)
- Imperial physical length measurements
- Analogue SWR meter scale calibration is poor
- Tendency to arrive broken or poorly calibrated

On the last point the evidence is only anecdotal... Well, the unit I played with has a poor calibration and Peter experienced a lot of problems with it himself. His is not an isolated experience if you search HAM forums.

Conclusion

The MFJ-269 seems to be designed quite well. I am sure with careful calibration it is capable of quite reasonable accuracy over HF and into VHF. I strongly suspect it would be quite difficult to design something more accurate without ending up building a true vector network analyser with log detectors and synthesised local oscillators. With recent advances in technology it might be possible to build such a device for about the same asking price, but I am sure the development costs would place its initial RRP closer to \$1k, making the MFJ-296 look like quite a bargain.

Is the MFJ-269 overpriced? Well perhaps. Especially in the light of the horror stories out there about some HAMs experiences with the unit. How many of them are due to "operator error" is unknown, but MFJ is very well known for having quality control issues, so it is likely that many are real hardware problems. Fortunately there is also a great deal of support available for the unit, with MFJ sending part kits out to repair blow-up or factory-bugged units. By virtue of its ubiquity (and from the earlier 259 and 259B units) the HAM community has plenty of resources for fixing busted MFJ-269s.

Would I buy one? If it was < \$300 AUD - yeah I would take the risk of getting a lemon. I would feel more comfortable if there was a circuit diagram in the manual, that way at least I could fix it easily enough. There are diagrams online that profess to be of the 269 or 259/259B, they seem pretty correct but I haven't extensively studied this loaner unit for comparison. There is a calibration procedure available, and one for the 259/259B as well from the original designer, but note that the 259 has 8-bit ADCs so the hex values displayed on the 269 and the pot numbers don't match this page - still it is a useful read and the document on the MFJ site seems to match the general guidelines when you convert to 12 bit numbers.

Unlike a VNA-solution the MFJ-269 isn't tied to a PC which is important for field work on antennas, but this is becoming less of a problem with USB-based VNAs that can run from a Netbook form-factor PC, perhaps it would be best to save the money and invest in a VNA as many of us already have a netbook PC, especially for use in the lab rather than just antenna work. Still, it would be nice to have it all in the one portable box like the MFJ-269.

73's ! VK2ZAY



DX NEWS From the Web (opdx)

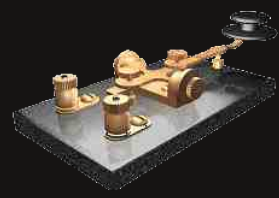

5K, COLOMBIA

A DXpedition is being planned to operate from the Laguna Grande de la Sierra, from where you get the legendary rock formation called Devil's Pulpit, the peak Sugarloaf Peak and Concave. Callsign will be 5K7SNC. This will be only a two day operation. Announced dates and hours of operation frequency are:

April 1st - 7140 kHz between 1700-2400z

April 2nd - 7140 kHz between 0000-1700z

QSL via HK3OCH. For more details and possible updates, visit QRZ.com under 5K7SNC.



5R, MADAGASCAR (IOTA Op)

Michele, IK5ZUI, will be active as 5R8UI from Nosy Be (AF-057) starting early March. He will stay there possibly for one year. More details are forthcoming.



7P, LESOTHO

Pista, HA5AO, will once again be active as 7P8AO from the Trading Post Lodge, Roma near Maseru, between March 8-22nd. Activity will be on the HF bands, 80-10 meters using CW, SSB and RTTY. He will be using an ICOM 7000 transceiver w/300 watt amp into a 10.2m wire vertical antenna with a SG-235 automatic antenna coupler. QSL via LoTW, or via HA5AO by the Bureau or direct. An online log search will be available on Pista's Web site at:

<http://ha5ao.novolab.hu>



8Q, MALDIVES

Alex, UX4UL, will be active as 8Q7IA from the Maldives (AS-013) between now and May 18th. Activity will be mostly CW and PSK. Currently Alex has antennas installed for 40/20/17 meters. QSL via UY5ZZ.



CO6, CUBA

Operators Luis/CO6LP, Orelvis/CO6LC, Yordany/CM6YAC, Carlos/ CO6CAC, Jose/CO6EC and CO6YWR will be active as T46A during the ARRL DX SSB Contest (March 6-7th) as a Multi-Single entry. QSL via CO6LC.



LZ123, BULGARIA (Special Event)

Members of the Balkan Contest Club (LZ1KZA) will operate with special event callsign LZ132GO between March 1-31st. Activity is to commemorate 132nd anniversary of the liberation of Bulgaria from Ottoman yoke by Russia. QSL via LZ1ZF. Special event station LZ132GO also counts for 10 points towards "St. Teodosii Tyrnovski Award":

<http://www.balkanclub.org/awards.htm>



ON30, BELGIUM (Special Event/Contest)

Egbert, ON4CAS, Secretary of the Belgian IARU Society UBA & Award Manager, informs that special event station ON30ON (Oscar November Thirty Oscar November) will be active during the months of March, April, September and October of 2010. Activity is to commemorate the 30th edition of the Belgian "ON Contest". The contest was first organized in 1980 to celebrate the 150th anniversary of the Kingdom of Belgium. Since then, the yearly event - lasting just four hours on a local Sunday morning - has become increasingly popular. QSLs for ON30ON go via the UBA bureau or direct to ON4CAS. A special certificate which can be achieved for free has been created in PDF format. Full details are available at:

<http://users.telenet.be/egbert.hertsen/on30on.html>



PACIFIC TOUR

Hugh, K6HFA, has announced that he will be in the South Pacific from early March until late April and plans to activate the following islands: Samoa (5W) - March 310th; IOTA OC-097 - Tonga (A3) - March 12th April 2nd; IOTAs include OC-049, OC-064 and OC-123 - Wallis (FW)- April 612th; IOTA OC-054 - Tuvalu (T2)- April 1321st; IOTA OC-015 - Fiji (3D2) - April 2326th; IOTA OC-016 or OC-156.

Hugh plans to be on CW, SSB and possibly RTTY using 100 watts into a multi-band vertical antenna (for 80-15m). Look for him on the IOTA frequencies or possibly other frequencies. Hugh plans to call by areas (EU, NA, SA, ASIA... etc..) per propagation. Callsigns are TBA. QSL via K6HFA. Look for more details to be forthcoming.



TI8, COSTA RICA

Operators Keith/W4KTR, Eddie/K4UN, Bob/W4BW, Lex/W4XO, Carlos/TI2KAC, Juan Carlos/TI2JCY and TI2ZM will be active as TI8M from Costa de Pajaros, during the ARRL DX SSB Contest (March 6-7th) as a Multi-? entry. QSL via TI2KAC, direct preferred but bureau "OK".



V2, ANTIGUA & BARBUDA

Alan, N3AD, will be active as V26M between March 4-7th. Activity will include the ARRL DX SSB Contest (March 6-7th) as a Single-Op/High-Power entry. Alan informs OPDX that he will definitely be on Thursday afternoon and evening and on Friday before contest. His activity will be on the HF bands only - 160/80/40m in evening and 20/15/10m during daytime. QSL via his home callsign.



YI9, IRAQ

Operators Dooley/W4VDW and Louis/KI4VEU are now active from Baghdad as YI9VDW and YI9VEU, respectively. Operations are anticipated to begin in late February or early March. Activity will be on 160-10 meters including the 30/17/12m bands. Plans are to also activate an EchoLink node. QSL YI9VDW to his home callsign W4VDW and YI9VEU via LoTW. Echolink is YI9VDW-R (node # 496161), on daily between 1200-1230z (or when you see it active!). HF activity will take place for YI9VDW between March 1-7th. Suggested frequencies are: 20m: 14125-14300 kHz SSB between 1500-1600z; 40m: 7100-7200 kHz SSB between 1600-1700z.



2M, SCOTLAND (Satellite Op)

Paul, 2E1EUB, will once again be active as 2M1EUB from March 20th for 7 days. He will be active on all the satellites from northeast Scotland in the Cairngorms National Park. Also, look for him on 160 and 80 meters. Checkout (QRZ.com) under 2M1EUB for more info.



The Council of Europe Radio Amateur Club will be activ March 12th to 14th with the call TP60CE in SSB, CW, RTTY, PSK, SATELLITE to commemorate the 60th Anniversary of the Convention of Human Rights.

QSL via F5LGF

Web site: <http://ewwa.free.fr>





THE DXCALENDAR

ANTARCTICA TOUR; VP8/A, VP8/G, VP8/H, VP8/O by W2APF, traveling aboard the ship National Geographic Explorer. He is visiting the Antarctic region until Mar 5. He will sign W2APF/C6A/mm from onboard the ship and W2APF/KC4 from the Antarctic mainland. He plans shore excursions on the Falklands, South Orkneys, South Shetlands and South Georgia Islands and will use the call VP8DML from there. An exact timetable is not known in advance. Learn more at: http://www.expeditions.com/Ship_Detail92.asp?Ship=20
QSL cards for all callsigns should be sent via W2APF

PRINCE EDWARD & MARION IS; ZS8M AF-021. ZS1HF has announced he will be active from Marion Island "from the end of April once the 'SA Agulhas' has returned to Cape Town". He says he is taking up "the position of radio/electronics technician for a year". ZS8M is expected to be QRV in late April-early May. Pierre will be active in his spare time, and will operate SSB, possibly with some RTTY. QSL direct to ZS1X.

1/3 PITCAIRN I.; VP6AL

QSL OK via eQSL or direct: c/o P.D.C Hahei, RD1, Whitianga, New Zealand.

1/3 NEW ZEALAND; ZL/G6PAA

He will probably visit both the North Island (OC-036, WLOTA LH-0069) and South Island (OC-134, WLOTA LH-0342). Activity will be 80-10 meters using CW, SSB, RTTY and PSK. He will use 100 watts into a dipole. QSL via his home callsign, direct or by the Bureau.

2/3 BELIZE; V31RI

by DL6RAI. QSL via home call, direct or bureau.

2/3 - 11/3 ST. LUCIA; J68JA NA-108

by W5JON. Activity will be on 160-6 meters (including 60m) on SSB. He will use an ICOM IC-7000, KL-400 Amp (350 watts) into the following antennas: ZS6BKW design multiband dipole, and a 3 element yagi on 6m. Activity will also include the ARRL International DX Phone Contest (March 6-7th) as a Single-Op/All-Band entry. QSL via W5JON.

3/3 - 10/3 COCOS (KEELING) IS; VK9 OC-003

by NL8F. Activity will be on 80-10 meters, plus 6 meters, and an entry in the ARRL International DX Phone Contest (March 6-7th). He will be using a vertical antenna. He does not know what his callsign will be, but he is hoping for VK9COF (or possibly VK9C/NL8A). QSL via K8NA.

3/3 - 2/4 RODRIGUES I; 3B9WR AF-017

from Cotton Bay, Rodrigues Island by G3LZQ. Activity will be on all bands 160-10 meters, probably and mainly CW, but with a focus on the lower band (QRN permitting). Look for him to be in the RSGB's 73rd Commonwealth Contest (March 13-14th). QSL via his home callsign.

3/3 AFGHANISTAN; T6LC

from Gardez in Takia Province By W4JJ. Mainly 40 and 20 meter CW/SSB. Check 1430-1800z. QSL via K4MJN.

3/3 GRENADA; J37BO

by K4LTA, including a Multi-Single entry in the ARRL DX CW Contest as J38A along with NK4N. QSLs via K4LTA.

4/3 - 9/3 NICARAGUA;

YN2EA, YN2UO, YN2MG and YN2TKI by WF5W (YN2EA), K5UO (YN2UO), NM5G (YN2MG) and WB5TKI (YN2TKI). They plan to operate CW, SSB and RTTY on 160-10 metres, and to participate in the ARRL DX SSB Contest as YN2EA (Multi-Single). During non-contest periods, they will have two stations active on all modes and bands. QSL for all callsigns via W5PF and LoTW. For information, look at <http://www.tdxs.net/yn2ea.html>

5/3 - 12/3 SAINT MARTIN; FS/KT8X

This will be a holiday style operation with an emphasis on the 30/17/12 meter bands using CW, SSB and RTTY. However, he does plan to enter the ARRL DX SSB Contest as a Single-Op entry. QSL route will be the "Logbook of The World" (LoTW).

5/3 - 16/3 ST. LUCIA; J6/G3PJT NA-108

Main activity will be concentrated during the RSGB Commonwealth Contest, outside the contest he will operate holiday style mostly on 80 and 30 metres CW.

5/3 - 24/3 THE GAMBIA;

C56KR by OZ8KR. Activity will be holiday style with operations on 80-10 meters SSB, using 100 watts into wire antennas close to the Atlantic Ocean. QSL via OZ8KR.

5/3 ANTARCTICA TOUR;

VP8, VP8/G, VP8/H, VP8/O and KC4 W2APF will be traveling on board the ship "National Geographic Explorer" heading to the Antarctica region. He is expected to be operating under the following callsigns (specific dates were not provided): W2APF/C6A/MM - While on board the ship "National Geographic Explorer"; http://www.expeditions.com/Ship_Detail92.asp?Ship=20/

W2APF/KC4 - While in Antarctic territories VP8DML - While in the territory of the Falkland Islands (VP8) including South Shetlands Islands (VP8/H), South Orkney's Islands (VP8/O) and South Georgia Islands. QSL all activity via W2APF.

8/3 THAILAND; HSØZJF AS-101

by ON4AFU. During his stay he plans to activate the Malay Peninsula East Group (AS-101) during this time-frame as HS0ZJF/8. He will also make a trip to Cambodia between February 2-15th, 2010, and be active as XU7AFU. All his activities will be on all bands but CW only. QSL via his home callsign.

9/3 - 16/3 ST. LUCIA; J6/G3PJT NA-108

from the north-east corner of St. Lucia. Activity will be holiday style using a K2 w/100 watts and vertical antennas. He plans to also be in the RSGB's 73rd Commonwealth Contest (March 13-14th). Look for him outside of the contest especially on 80 and 30 meters. QSL via his home callsign.

9/3 - 18/3 ANTIGUA & BARBUDA;

V25WY and V25OP by W4OWY and W9OP. Activity will be on 160-6 meters using CW, SSB and RTTY. QSL via their home callsign or by the Bureau. Logs will also be uploaded as before to LoTW and eQSL.

9/3 - 22/3 MARSHALL IS; V7/N4XP

from Kwajalein. Look for him to be active on 160-10 meters using CW and SSB. He plans to be active on 60 meters this trip. QSL via his home callsign.

10/3 - 17/3 MONTSEERRAT; VP2MCC NA-103

by G4FAL including an entry in the RSGB Commonwealth Contest (13- 14 March). The contest is for operators located within the Commonwealth or British Mandated Territories, so Nick says he "will be keen to work other stations" outside the BERU event. Activity is likely to be restricted to 80-10 metres CW, however if he can organise an aerial for 160m then he may be able to try some morning greyline contacts with Europe on CW on 15 or 16 March. QSL via G4FAL (direct or bureau) and LoTW.

10/3 - 23/3 JUAN FERNANDEZ IS; CEØZ/LA9SN

from Robinson Crusoe Island. He plans to operate mostly CW on 80- 10 metres. QSL via operator's instructions.

11/3 - 24/3 SAINT MARTIN; TO5SM NA-105

by F6BFH, to be active on the HF bands using CW and SSB. QSL via F6BFH, direct or by the Bureau.

12/3 - 23/3 NEW ZEALAND; ZL4TY and ZL4M OC-203

from Stewart Island by VK4DXA, ZL4PW and ZL4PA. They plan to have 2 stations using verticals for 160-30 meters and a Spiderbeam for 20-10 meters. They intend running barefoot unless they can obtain a solid-state amplifier. The following suggested frequencies (+/- 10 kHz, QRM, QRN & propagation permitting) have been announced:

Band	CW	SSB	RTTY
----	-----	-----	-----
160m	1820	1845	
80m	3525	3785	3580
40m	7025	7165	7038
30m	10115	10145	
20m	14025	14260	14085
17m	18080	18145	18105
15m	21025	21295	21085
12m	24895	24945	24920
10m	28025	28475	28085 kHz

QSL Info: They need a minimum of 2 USDs or 1 x IRC (please, 2010 issue) for a direct reply. Any donation sent with your QSL request will be greatly appreciated. Cards with insufficient funds or invalid IRCs will be sent via the bureau. All logs will be uploaded to LoTW following the DXpedition. QSL ZL4TY via VK4DXA; by the VK Bureau or direct to: Ray Crawford, 53 Moore Street, Kingaroy, QLD 4610, Australia. QSL ZL4M via ZL4PW; by the ZL Bureau or direct to: Paul Ormandy, 13 Swift St., Oamaru 9400, New Zealand. For more details and updates, visit their Web page at http://www.zl4pw.orconhosting.net.nz/OC203/si_index.htm

16/3 - 23/3 MOROCCO;

5C2J, 5C2L, 5C2SG, 5C2P, 5C2W and 5C2Q

by IK7JWX (5C2J), I8LWL (5C2L), IZ7ATN (5C2SG), IK2PZC (5C2P), IK2DUW (5C2W) and IK2GPQ (5C2Q). Activity will be on all HF bands and 6 meters, using CW, SSB, PSK31 and RTTY. QSL via their home callsign.

16/3 - 23/3 JUAN FERNANDEZ IS.; CEØZ/LA9SN

Activity, possibly to the 26th, 2010, will be on 80-10 meters using mostly CW and 100 watts. QSL via his home callsign (may change). For updates, visit his Web page at <http://www.la9sn.com/>

16/3 - 4/4 ANTIGUA & BARBUDA; V21ZG NA-100

from Antigua by DL7AFS and DJ7ZG. Activity will be on 80-6 meters with operations mainly on RTTY, PSK and SSB. They plan to look for JA stations and QRP stations. QSL via DL7AFS.

17/3 - 20/4 E. KIRIBATI; T32 IOTA NEW!

SM6CAS, G3KHZ, G4EDG and K9AJ plus five Kiribati Government officials, will be leaving Christmas Island on a long voyage to the Southern Line Islands. They plan to stop and operate from four IOTA new ones, namely Malden Island (OC-279), Starbuck Island (OC-280), Caroline Island (OC-281) and Vostok Island (OC-282). They plan to be active on each island for four days. QSL direct via SM6CAS. The voyage will be almost 1,800 nautical miles. Further information is expected in due course, bookmark <http://t32line.webnode.com/> for updates.

20/3 UGANDA; 5X1NH

by G3RWF. Activity will be on the HF bands. He prefers CW and likes the Digital modes (PSK and RTTY), but may work SSB whenever signals are good enough. QSL via his home callsign.

22/3 - 8/4 GREENLAND; OX/KØKU NA-018

from Thule by NØRC. Activity will be limited as work permits, but he plans to be on every other day and try to get on the air for contest weekends, but he cannot guarantee this. Look for the log to be uploaded to LoTW and EQSL. QSL direct to NØRC or by the Bureau.

26/3 - 31/3 CANADA; VYØV NA-231 NEW ONE!

from East Pen Island by VE3LYC. The operation is scheduled for 3 days between 26 and 31 March. He is looking for any possible donations towards the cost of this difficult project. Support can be sent to him by PayPal at tiberius.trifu@gmail.com. More information about his preparations and QSLing will be posted on the VY0V page at QRZ.com

26/3 SOUTH SHETLAND IS; XR9JA AN-010

New dates again due to a change in the Navy ship schedule. from Arturo Prat-Greenwich Island-South Shetland archipelago, WW Loc. GC07FQ) by XQ5CIE, CE6UFF, F6DXE and CE5COX. Activity will be on 160-6 meters using CW, SSB, PSK31 and the AO-51 Satellite. QSL via CE5JA. For more information, go to <http://www.ce5ja.cl/> or www.qrz.com/

27/3 ST. MAARTEN, SABA, ST. EUSTATIUS; PJ5NA NA-145

from St. Eustatius by K1NA. When not taking part in contests, he will concentrate on 30, 12 and 17 metres, as well as on 160, 80 and 40 metres during his nights. QSL via K1NA, (100% QSL direct only with SASE). No bureau cards will be answered. DX stations MUST have SASE or SAE with 1 USD. No IRC! USA stations SASE only.

28/3 - 31/3 OGASAWARA; JD1BNN

by JF3MYU. He is expected to be there with three other operators who will be staying long (hopefully more details will be forthcoming). He will be focused on the WARC bands. QSL is "OK" via JARL Bureau, but write JD1BNN on your QSL (so it can be sorted easily). Also, you can receive his QSL direct if you send your QSL to his address: Kirk Itaya, 5-1-35, Daikaidori, KOBE, 652-0803 JAPAN. Please enclose SAE plus sufficient return postage. For NA, SA, EU and AF include one new IRC or 2 USDs. For Asia, one IRC or 1 USD.

28/2 - 14/3 ARUBA; P4ØA

by KK9A. Activity will be on 160-10 meters using CW and SSB. He will also be in the ARRL DX SSB Contest (March 6-7th) as a Single-Op/All-Band entry. QSL via WD9DZV. His QSL Manager will join him between March 7-14th. He will operate mostly CW using the callsign P4ØD.

28/2 - 14/3 ARUBA; P4/WA2NHA

Activity will be on 80-10 meters mainly CW. QSL via his home callsign.

31/3 GUINEA-BISSAU and SENEGAL; J5UAP and 6W2SC

by HA3AUI. He will spend his holidays at the border between Senegal and Guinea-Bissau. He will be QRV on 160m-10m, prefers digital modes (CW/SSB upon request) and uses a K3 transceiver with 500 watts amplifier, a 5 band Spiderbeam and verticals. QSLs direct via HA3AUI. More information can be found on his website at <http://cqafrika.net/>

31/3 DOMINICA; J79XBI NA-101

by SM0XBI. He will operate SSB on all bands. QSL via SM0XBI, direct or bureau (but LoTW preferred).

31/3 CANADA; VG, XK, XJ and VX

The following prefixes will be available for use to commemorate the 2010 Olympic Winter Games in British Columbia. Canadian stations with a VA prefix can use VG, VY can use XK, VO can use XJ, and VE can use VX. Known announced activities are: VX9NC - VE9NC will operate during that time using primarily digital modes on all HF bands. QSL via his home callsign. VG7G - VE7XS will be operating during this time. See below. VG7W - VE7OM will be operating as VG7W between now and January 31st.

31/3 CANADA; VG7G

The Vancouver Olympics Amateur Radio Group (VOARG) will activate three special calls to celebrate the Olympic Winter Games and Paralympics which will take place in Vancouver/British Columbia in Feb/March 2010. This is the third special call. A website will go online soon, all logs will be uploaded to the LoTW. QSL cards can be sent via bureau or direct to: VOARG, 9362-206A St, Langley/BC, V1M 2W6, Canada.

April ANNOBON I; 3CØC AF-039

by EA5BYP and EA5KM for 15 days. They will operate CW, SSB and RTTY on 160-10 metres, with an emphasis on the low bands and CW. QSL via EA7FTR, direct or bureau (QSLing policy on the website). All of the QSOs will be uploaded to LoTW one year after the expedition. Further information can be found at <http://www.3c0c-annobon.com/>

10/4 - 18/4 VIET NAM; 3W6C AS-185

from Con Co Island by HB9BXE and a large group of operators from Switzerland, Germany and Vietnam will be running four stations 24 hours a day. Further information is expected in due course. For the time being, please visit <http://www.3w6c.qrv.ch/>

14/4 - 19/4 TAIWAN; BW1/K8QKY

Activity will be on 160-6 meters using CW. QSL via his home callsign.

25/4 - 6/5 MARTINIQUE; FM/F5TGR

Activity will be limited to his spare time (holiday style) on 40-10 meters using CW and SSB. QSL via his home callsign, direct or by the Bureau.

GO SWR - 50 MHz DX NEWS BY OZ6OM

Cocos, VK9c. Tim, NL8F, will be heading to the Pacific again. He will start at Cocos (Keeling) Island between March 3-10th. Activity will be on 80-10 meters, plus 6 meters, and an entry in the ARRL Inter-national DX Phone Contest (March 6-7th). He will be using a vertical antenna. Currently, Tim does not know what his callsign will be (apparently it takes time for the WIA to process callsigns), but he is hoping for VK9COF (or possibly VK9C/NL8A). QSL via K8NA.

Denmark, OZ. Hello Guys, I (OZ6OM) will be QRV in the Nordic Activity Contest Thursday evening (March 11 th.) between 18 and 22 UT.

I intend to be QRV from JO55EJ at an alternate QTH running 100 w. into a 5 or 6 element Yagi.

In any case I intend to keep activity round 50.173 MHz (SSB/CW) and 50.230 MHz / 50.236 (JT6m).

(The reason I'm operating this way is, my attempt at setting up reasonable antennas at my QTH have so far ended in a law suit (Latest, case appealed to the domestic court after a no from the council review board). - so the antenna at my QTH is very modest at this time. The given permit says maximum hight at 1.8 m. agl.)

Hope to see You down the log ... vy 73 de Matt OZ6OM

St. Lucia, J6. Look for John, W5JON to be active as J68JA from Marigot Bay, island of St. Lucia, Grid FK93 on 2-11 March, 2010. QRV 160-6 meters (also 60m), including a Single-Op entry in the ARRL DX SSB Contest (6-7 March). His equipment will consist of an ICOM IC-7000, KL-400 Amp (350 watts); Antennas: Alpha Delta DX-LB and DX-EE Dipoles, and 3 Element yagi on 6m. As in the past, XYL Cathy (W5HAM) will be very busy pool side. QSL via home call. (Andy N8OFS GOT6???)

Dodecanese, SV5. Willi, DJ7RJ will be active from Kos Island from 24 February until 17 March. He will operate CW and SSB on 160-6 metres, with a focus on the low bands. QSL via home call.

Antigua, V2. March 9 to March 18 by W4OWY (V25WY) and W9OP (V25OP). We plan to operate CW, SSB and RTTY on 160-6 meters. QSL via home calls, direct, bureau, also LOTW and eQSL. Tnx Bob W4OWY / V25WY (Maurice F5NQL)

Contest, Open / WW.

What to do on a tuesday evening ?

- Well the 4th. Tuesday in the month brings You "The 50 MHz Open"

- This month thats Tuesday - the 23 rd. 18 - 22 UT.

- You could help participants out with some QSO's

- or participate Your self ...

You may find the rules for "The 50 MHz Open" here and check out the standings here.

- so are You keen to give "The 50 MHz Open" a try ?

Hope to see You down the log - and Your log ...

Vy 73 de Bjørn/"Matt" OZ6OM 23 Mar. 2010

Morocco, CN. Alfredo, IK7JWX, and a team of operators will activate the city of Essaouira and Agadir, between March 16-23rd. Operators mentioned (with callsigns) to be active are: Alfredo/IK7JWX (5C2J), Leo/I8LWL (5C2L), Simon/IZ7ATN (5C2SG), Ruggero/IK2PZC (5C2P), AntoNello/IK2DUW (5C2W) and Michele/IK2GPQ (5C2Q). Activity will be on all HF bands and 6 meters, using CW, SSB, PSK31 and RTTY. QSL via their home callsign.

Maledives Islands, 8Q. Dan, HB9CRQ, did send MMMonVHF an first Pre-Announce for the upcoming EME Expedition to th Maledives Islands in march 2010. Operator will be of Pierre, HB9QQ and Dan, HB9CRQ and maybe other Members of the HB9Q Team. Mainwork will be 144 MHz but as well 6m and 23cm band will be joined. If there are more Operators maybe as well 70cm will be activated (if any OP will have interest to join the Team please pass an info to Dan, HB9CRQ). Flights and Bungalows are booked already. Soon MMMonVHF will spread out more detailed informations (<http://www.mmmonvhf.de/latest.php?id=2896>) tnx to Dan, HB9CRQ, Team of HB9Q direct to MMMonVHF

Maledives Islands, 8Q. More. Here is some preliminary information about the upcoming 8Q7QQ 6m EME DXpedition March 24-31, 2010. Pierre HB9QQ has been very busy optimizing the 6m EME station he will be taking next spring for his JT65A operation. He will be using a low noise external preamp, 500w Falcon amplifier and a 7 element yagi overlooking the ocean. Watch for details to be coming in the future, but plan now to be available for this great chance to contact a rare one! There are some great horizon-only windows for NA stations with Pierre while he has ground gain on the horizon at the same time! EME CNDX also are optimum during their period of operation ;-)
GL and VY 73, Lance

Ogasawara, JD. Kirk, JF3MYU, will be active as JD1BNN between March 28-31st. He is part of the "JD1 Project 2010" and is expected to be there with four other operators who will be staying long. Kirk's activity will be focused on the 30/17/12m bands, SSB, some CW and 6 meters. QSL is "OK" via the JARL Bureau but write JD1BNN on your QSL (so it can be sorted easily). Also, you can receive his QSL direct if you send your QSL to his address in Kobe, Japan: Kirk Itaya, 5-1-35, Daikaidori, Kobe, 652-0803 Japan. Please enclose SAE plus sufficient return postage. For JA stations, SASE, please. For NA, SA, EU and AF include one new IRC or 2 USDs. For Asia, one IRC or 1 USD

Guadeloupe, FG. Serge FG/F6AUS, is working on 160m-6m from Guadeloupe until March 2010. He will sign TO4D in the WWDX CW Contest. QSL via homecall. *

South Shetland Isl., VP8H. Luis XQ5CIE, Carlos CE6UFF, Didier F6DXE and Dago CE5COX will be active from the Chilean naval base Arturo Prat on Greenwich Island (WW Loc. GC07FQ), South Shetland Islands, around 1-2 February until around 27-28 February as XR9JA.

They will be active on 160-6m SSB, CW, PSK31, and Satellite AO-51 QSL via CE5JA (Radio Club de Concepcion, P.O. Box 2545, Concepcion Chile). All QSLs received direct please include recent SASE or 2 USD \$; QSL received via Bureau will be returning by the same way All QSL will be 100% guaranteed. Further information can be found at: www.ce5ja.cl/ also www.ce5ja.cl/xr9ja_ingles.php

South Shetland Isl., VP8H. [Update]. By the time you read this, a team of operators, from the Concepcion Radio Club (CE5JA), should be operating from Arturo Prat Chilean Navy Antarctic Base on Greenwich Island on the South Shetland archipelago (WW Loc. GC07FQ), between now and the end of March. Their callsign will be XR9JA. Activity will be on 160-6 meters using CW, SSB, PSK31 and the AO-51 Satellite. Suggested frequencies are: CW - 1834, 3504, 7004, 14024, 18074, 21024, 24894 and 28024 - SSB - (*), 3780, 7078, 14200, 18145, 21295, 24995 and 28475 kHz 6m - 50115 - Please note that ALL CW contact will be done with a PC (due to the absence of their CW operator). They request to: "Be patient with us! Will try to do our best and certainly we will have enough time." QSL via CE5JA. For more information, go to: <http://www.ce5ja.cl>

Antigua, V2. Operators Babs/DL7AFS and Lot/DJ7ZG will be going on another DXpedition, but this time to the Caribbean region. Look for them to be active as V21ZG from Antigua between March 16th and April 4th. Activity will be on 80-6 meters with operations mainly on RTTY, PSK and SSB. They plan to look for JA stations and QRP stations. QSL via DL7AFS.

Quadrifilar Helix Antennas

By dimoni

What is a Quadrifilar Helix Antenna (QHA) ?

Simply - It's the best antenna to use for APT satellite reception - the featured antenna is depicted on the left.



To paraphrase M. Walter Maxwell

"It comprises two bifilar helical loops oriented in mutual orthogonal relationship on a common axis. The terminals of each loop are fed in antiphase and the currents in the two loops are in phase quadrature. By selecting the appropriate configuration of the loops, a wide range of pattern shapes is available". The basic form of resonant QHA was developed by Dr. C. C. Kilgus of the Applied Physics Laboratory, John-Hopkins University, Silver Spring, Md. and published in December 1970 in "The Microwave Journal". Since then a lot of research has been done into the number of turns and length/diameter ratios. All of these affect the radiation pattern. The "traditional" fractional turn design produces a cardioid radiation pattern. It has been found that tall narrow QHA exhibit a "shaped-conical" pattern with high gains to the horizon and decreased gain overhead, which is much better suited to APT ground stations (See polar diagram examples). Most of the published data and designs on narrow antennas however have been more suited to UHF and do not translate well to 137.5Mhz. One of the best is a narrow 5 turn, but at the frequencies we are interested in would make an antenna 7 metres high!

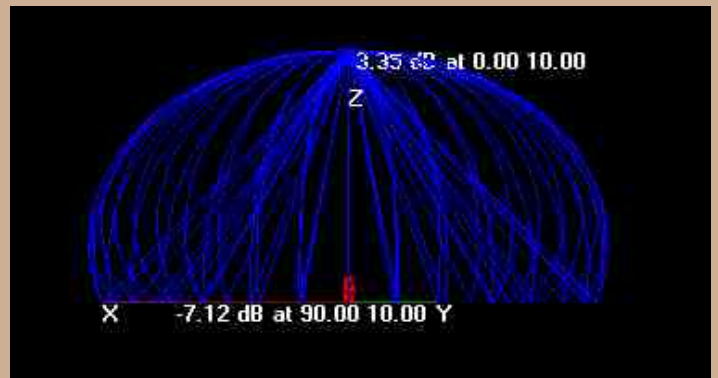

A traditional 1/2 turn design

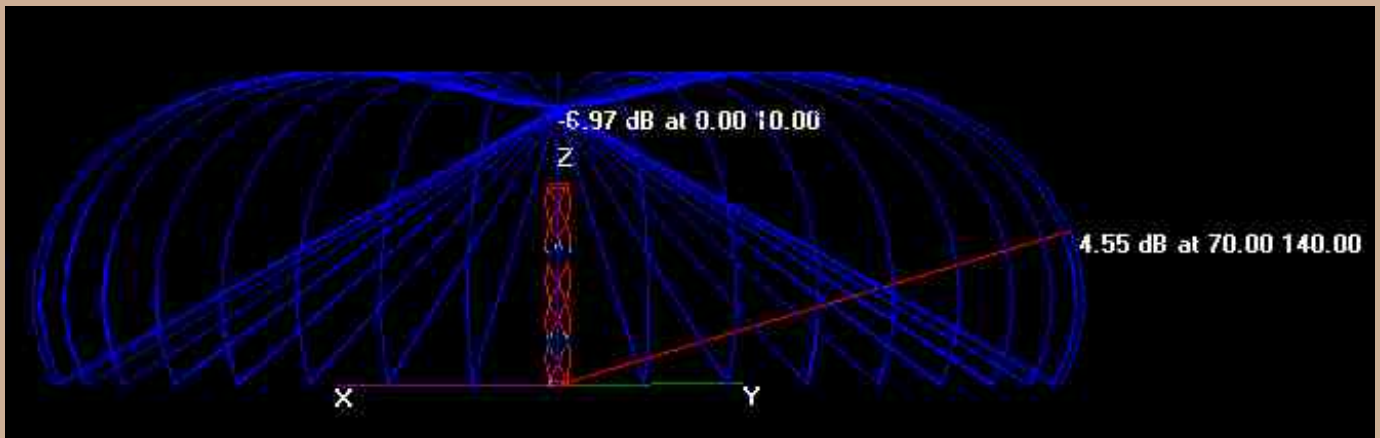

A tall narrow multi-turn design

A Solution?

This design came about in the search for better gain at the horizon and yet still make construction easy. After a lot of discussion, experimenting and some frantic NEC modeling John Boyer came up with the dimensions for this one.

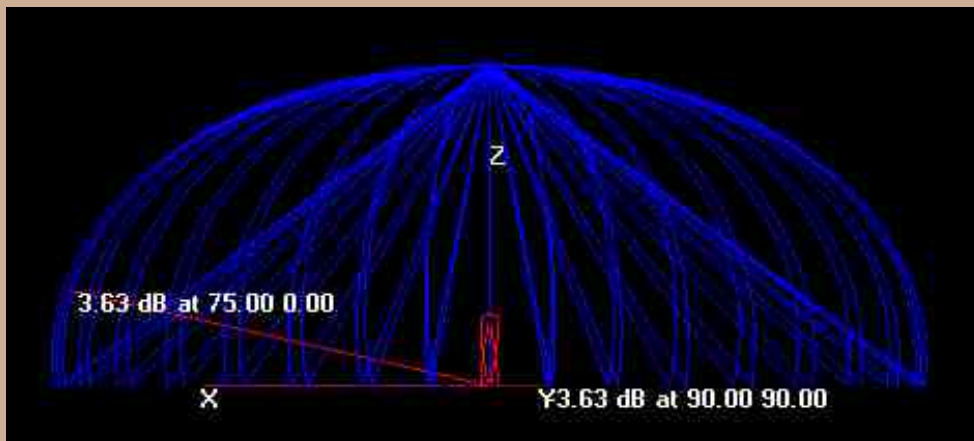

As you can see from the polar diagram above, this model exhibits a good compromise between the two previous examples. The +dB figures give the direction of highest gain, the - figures the direction of greatest loss.

John and myself have both built this one and find it has excellent reception properties. Its quite easy to get full horizon to horizon passes!

Try it - you'll not be disappointed

Construction notes and dimensions

The finished model should look like the one labeled "Tall narrow QHA" at the top of this page.

Element Dimensions

- Mast - 1.5m of 32mm (1 1/4") PVC waste pipe.
 - Elements - 8mm (3/8") mini-bore soft copper tube
 - 8 copper elbows for the corners.
 - 2 - 190mm lengths - bottom horizontal tubes
 - 2 - 903mm lengths - short helix elements
 - 2 - 1002mm lengths - long helix elements
 - 4 - 90mm lengths - top horizontal elements
- Note - these are cutting dimensions and assume that 90 degree elbows NOT bends are used - The dimensions on the drawing are from centre to centre of the respective elements - you may have to adjust your cutting sizes accordingly.

- 4 self-tapping screws for feed.
- Suitable length of RG58 or UR43 for balun and feed.
- 32mm cap to plug top end of mast.

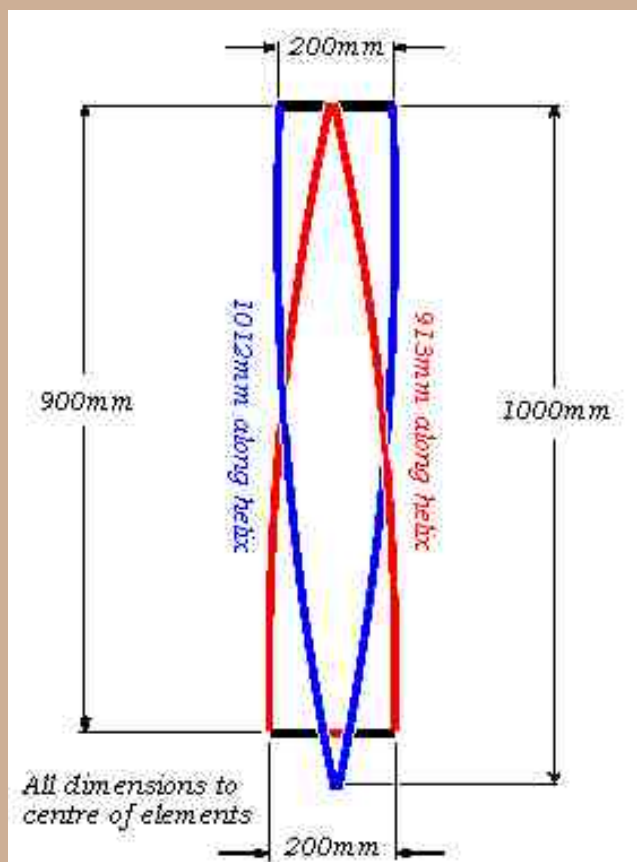

Drill 4 - 8mm holes at 90 degrees to each other 25mm from the end of the mast - make sure the holes are Square and in the same plane!

Mark and drill the bottom holes remembering they are in opposing pairs spaced 100mm apart - you're advised to check the measurements at least twice before drilling!!!

Drill a 7mm hole near the top of the mast for the cable entry.

Drill pilot holes in the 4 top elements for self-tapping screws and assemble top tubes, push coax through hole and make top connections with screws. Wrap the coax 4 times around the mast and tape/glue in position (balun).

Push the elbows onto the top tubes and measure from the centre of each leg - it should be 200mm, NB -you may have to cut more off if you used swept bends rather than tight 90 degree elbows.

Assemble bottom tubes, make sure they are central and square to top tubes.

Bend helices to suit - tip - try and find a former of some type; a suitable log or large pipe makes the bends nice and neat.

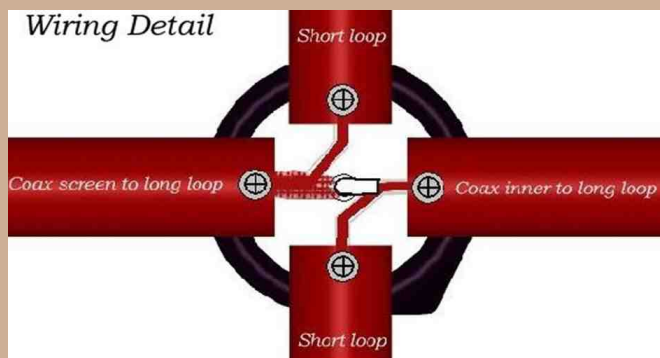

When your happy with the shape solder up the elbows. It should appear circular when viewed from the end.

Check the connections and cap the top end of the pipe. The copper tubes can be fixed to the mast using glue/silicon sealer and/or tape - make sure you seal the coax entry hole.

Push a suitable piece of wood up the bottom end to avoid crushing the PVC tube too much when clamping to the mast.

I hope you'll give it a try - it really is worth the effort.

2Mtr version

Here are the dimensions for a 144-146Mhz version

Diameter both loops 188mm

Long loop height 950mm, helix length 961mm

Short loop height 850mm, helix length 863mm

It doesn't scale very well for 435Mhz - but I'm working on it!

Best 73 ! Dimoni

MAKE YOUR OWN PRINTED CIRCUITS

By EI 9GQ

To make smart looking PCB's, all you need is: A computer, a laser printer, copper clad board, etchant, a clothes iron and some Epson glossy photo paper. You can buy special film for making PCB's, but I have found that the Epson paper gives better results. I use Epson photo quality glossy paper for inkjet printers.

Draw the PCB track layout, using a CAD program or a standard drawing program. Remember to reverse the image before printing. Most drawing programs have a 'flip horizontal' function. Print the image on normal A4 paper to make sure that it is the correct size. Check the layout carefully.

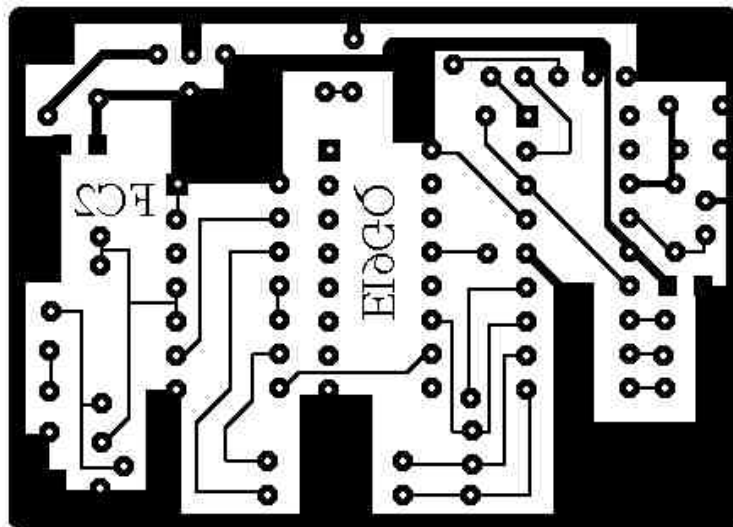

PCB LAYOUT

Use a laser printer to print the image on the glossy side of the photo paper. Clean the copper clad board with steel wool or very fine wet sandpaper. Dry the board thoroughly. Make sure that the board is clean and free from fingerprints. Place the photo paper face down on the copper clad board. Use masking tape to hold the paper in position. Don't use vinyl tape. Place the board on a flat surface. You will be using a very hot iron, so don't use the dining room table. I use the back of an old telephone directory. Use a hot clothes iron to transfer the track pattern from the paper to the copper board. Don't be afraid to use lots of heat and pressure. Allow the board to cool. Don't be tempted to lift the paper. Put the board in a container full of warm soapy water. After about twenty minutes the paper will begin to dissolve and disintegrate. Carefully remove the paper from the copper board. Rinse under a cold tap to remove paper residue. You may need to touch up any broken tracks with an etch resist pen. I use a fine Staedtler laundry marker.

BEFORE ETCHING

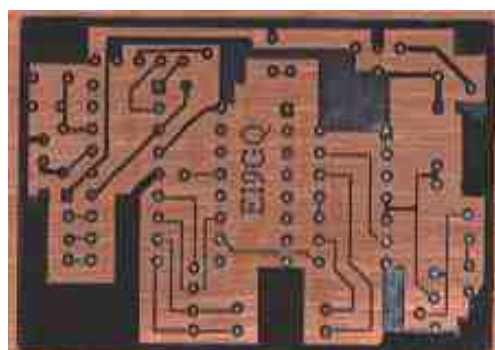

Etch the board in a Ferric Chloride etching solution. You can buy the etchant in liquid form or as anhydrous Ferric Chloride powder. Follow the instructions. NEVER add water to dry Ferric Chloride. Don't get any on your clothes.

AFTER ETCHING

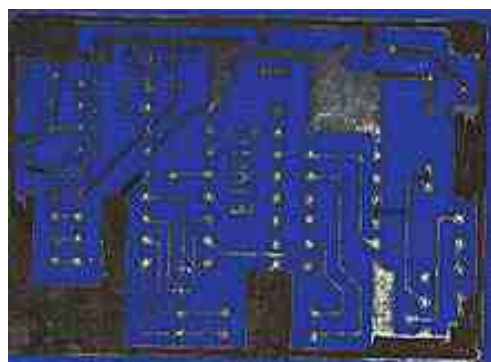

PCB

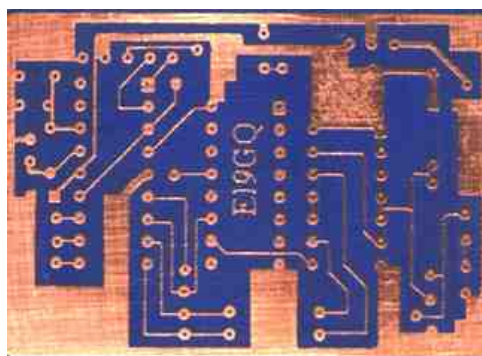

After etching, rinse the board under a cold tap. Remove the etch resist with some steel wool. Dry the board. Use a 0.8 or 1.0 mm drill to make the holes for component leads.

CLOSE UP

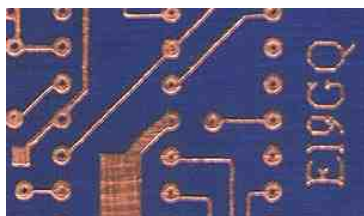

The close up picture shows that the tracks are not as clear and well defined as they would be if the board was produced by photographic methods.

The procedure for making double sided boards is a bit tedious. Coat one side of the board with aerosol paint or clear lacquer. Etch the other side of the board as for a single sided board. Remove the paint or lacquer. Drill the component lead holes. Paint the etched side of the board. Then etch the unetched side of the board as for a single sided board. It is difficult to line up the two sides correctly. Use the component holes as a guide.

END RESULT

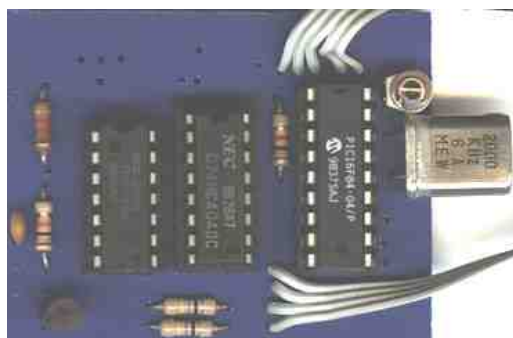

I have used this method to make PCB's for both DIL and surface mount IC's with 0.05 Inch pin spacing.

My laser printer is an old Apple LaserWriter II NTX (300dpi.) If you don't have access to a laser printer, use an inkjet printer to print the layout on ordinary paper, then copy the image to the Epson paper, using a photo copier. I haven't tried this method but it should work.

I have also had good results with an OKI LED printer. I have found that Xerox paper works just as well as the Epson paper. I buy it in packs of 20 sheets. COLOR INKJET PHOTO PAPER HIGH GLOSS

73 de EI9GQ

The History of Torre Bert From Astrosurf



Introduction (I)

From 1957 many young people were watching the first space missions at TV, and read the news showing the equipment used by the first ground stations to receive signals transmitted by artificial satellites. Soon they see the first manned Russian and American spacecrafts orbiting around the Earth. For some of these amateurs it was the opportunity to experiment the first equipments directed to space communication.

On April 1965 the Reader's Digest published the exciting adventure of two amateurs listening to space illustrated with the sketch displayed at right, article in which author J.D. Ratcliff explained how two young Turino, the Judica-Judica-Cordiglia brothers had set up a tracking satellite station of their own, Torre Bert, to listen to the first space communications between the Russian or American spacecrafts and the ground stations.

At that time of its release this story looks to me like a dream : with some equipment amateurs seemed able to listen to space communications, and even get telemetry sent by spacecrafts. We could work at home like did engineers at Houston ! This reality fascinated me !

It is thus almost at that time that this new fact (added to other stories) convinced me to become an amateur radio. In this way, if I did become an astronaut, I had at least the opportunity to listen to their communications.

But time running, two decades later my dream of kid became to broken in parts as other echoes reached my antennas. The Judica-Cordiglia brothers hadn't realized all they claimed. Was is possible ? Now helped with my scientific and amateur radio backgrounds I had the capability to verify most of their alleged claims.

This is this investigation that I would like to present you below. Not the complete Judica-Cordiglia brothers story that you will find in its complete version on Lost Cosmonauts, a fine website maintained by Giovanni and Mario Abrate. I would like only to highlight some facts and exercise your critical sense one more time. Report and criticals.

Torre Bert and the Zeus network

In the Northern Italy, between 1957 and 1965 two young Turino brothers fan of communication but not amateur radio, Achille and Giovanni "Gian" Battista Judica-Cordiglia set up the first amateur tracking station, "Torre Bert". Their goal was to pick up the first telemetry signals and other downlinks data from the first satellites launched by Russia then by NASA. They were eventually able to record the conversations between the cosmonauts and astronauts and their respective ground stations. They set up the first amateur world network of space tracking stations and erected not less than 21 antennas, including phased-array dipoles, and used the first mobile tracking unit installed in a break (station wagon). They were the pioneers in all fields, soon caught up by radio amateurs ! How all this adventure began ?

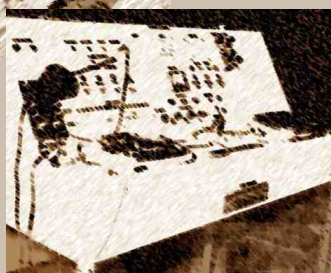

Sketches made by the author from pictures showing the Torre Bert station. At left Gian Battista (sitting at desk) and his brother Achille Judica-Cordiglia. At center the tracking room. At the best time the team would have gathered up to 20 operators. At right the audio processing system desk.

While Jodrell Bank invested 1.6 million sterling pounds (\$2.3 millions of 2000) to track satellites, that USAF spent 15 millions dollars at Tyngsboro, Mass., to build his Haystack radar (used later by NASA in his Orbital Debris Radar Calibration System ODERACS), and that a Turino industrial built a parabolic dish at 2 millions lira (\$900), our two young amateurs had only 18,000 lira or a little more than \$8 to spend. So the only solution was to build themselves their equipment.

With an extraordinary ingenuity they achieved their objective in a couple of years and were able to track any satellite passing nearby since the first Sputnik. In 1965 they created the Zeus network that counted 17 stations spread over the world and hooked by shortwaves. Their installation was so sophisticated that there were able to forecast 12 hours ahead that Lunik IV launched by Russian to the Moon should miss its target by 8000 km (5000 miles). In fact it flew 8497 km off the Moon.

Sketch showing a six-dipole array used at Torre bert.

To pick up these messages Torre Bert used up to 21 antennas. The one displayed at left is a six-dipole array that could be tuned on 108, 137, 145.8 or 405 MHz. They used also a single helical antenna placed at center of the large ground plane. It was controlled manually using a wheel installed in the tracking room. This antenna system offered a 7.8 dB gain over a single Yagi. This gain was so low that even the Gian Battista Judica-Cordiglia considered this system as unsuited or almost to pick up space communications as it was often at the limit of the background noise. But we will see in a moment that these frequencies hide other mysteries. During its short existence, it seems that Torre Bert recorded some sensational messages from space. But not everybody share this opinion, and personally, even having not had the opportunity to listen all tapes, some technical objections can already be presented. Here are some examples of recordings made by Torre Bert, beginning with the most famous of them, a recording of John Glenn made in 1964.

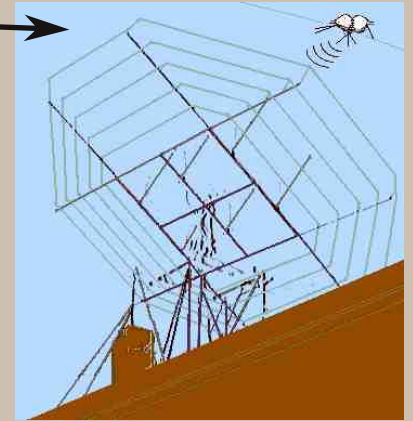

If by some ways the Torre Bert installation displayed some attracting but useless devices (display and vector maps) or had to manually rotate their antenna, the Judica-Cordiglia brothers had the right telemetry receivers, the suited antennas and, last but not least, the know-how to build a functioning receive space communication station. Here is an example of their skills.

In 1964, they won a TV-game dealing with the space conquest and were rewarded in receiving a gift of 1,8 millions lira (about \$830 of 2000). Our young Turino brothers took advantage of this opportunity to visit the USA. It was written that they had the support of the U.S. Embassy in Roma, thanks to the help of their Scientific Attaché Mr Walter Ramberg who organized for them a meetings with some NASA specialists of space communications, including M.Haussman, in presence of an italianse/american translator named Alberto Rossoto. According to some writers and a film recently released on european TV, this is at this occasion that the two brothers visited NASA space centers of Huntsville, Cape Canaveral, Houston and Beltsville where they did the admiration of American engineers by the extent of their know-how. They played tapes they had made of John Glenn's conversations with Capcom recorded during the Friendship 7 mission of 1962.

According to various sources, Haussman and other NASA officials were astounded. Harry J. Goett, director of the Goddard Space Flight Center said to their translator that "They have done a remarkable job" but was afraid that amateurs were able to discover secret working frequencies. NASA never announces the audio frequencies while the spaceflight is not ended, for fear of causing jam on frequencies or other problems. They thus asked to the youngs how they determined this special frequency in the L-band. "Easy", the Judica-Cordiglias said, "we saw a pre-flight picture of the Glenn capsule and we figured the frequency from the size of the capsule's antenna !...".

Note for the anecdote, that convinced that NASA was subjugated by the know-how of our two brothers, these latter requested to NASA the permission to get two of their secret space frequencies in exchange of what our two brothers would give them two space frequencies used by Russia. Of course, NASA engineers accepted the deal and give them what they asked, at the greatest pleasure of our two brothers.

Nowadays, when we want to know at what frequencies work a satellite or a spacecraft, our first reflex is also to check the radios in the command module or to deduce from the external antenna sizes what could be its working frequency. With some habit we can easily answer to such a question, maybe not to the right frequency but close to some MHz.

At left space docking between the unmanned spacecraft Agena and Gemini 8 flired by Neil A. Armstrong and David I. Scott on Mars 16, 1966, some years before Armstrong is enlisted in the Apollo XI crew. From the drawing at right we learn that the can-like antenna that we see above the craft was a 7 ft long and retractable L-band (1-2 GHz) antenna. With such information some bright amateurs built the first receiving system to capture telemetry and other signals from the first manned space missions. Documents NIX and NASA History.

Beside of their extensive work, the Judica-Cordiglia brothers claim that they recorded alleged communications of cosmonauts in distress, including a woman, or conversation that do not meet the declarations of authorities. Here are some examples that I voluntarily shortened because the problem is not only in the content of these messages but most of all in their existence itself as you will quickly understand.

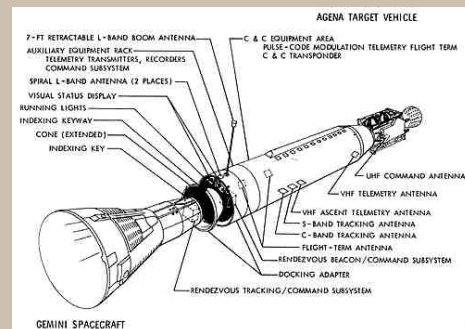

Claims of recordings of cosmonauts in distress

On November 28, 1960 Torre Bert should have picked up this enigmatic message in Morse code: "SOS TO THE WHOLE WORLD". The message was transmitted from a moving spacecraft, that was, according to the two brothers, confirmed by its Doppler effect, and was sent three times. According to Judica-Cordiglia brothers, amateurs in Germany and Texas received the same message.

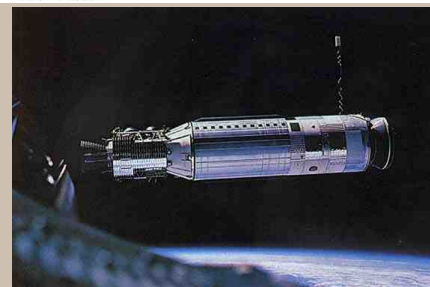

Three days later, Russian recognized that one of their launch failed, but they didn't make allusion to a human passenger. A similar recording was picked up on May 17, 1961 (according other sources the period is somewhere between 16-23 May) coming from a crew of several cosmonauts requesting assistance, among them a so-called female "cosmonaut" voice telling that there was flames and a fire around her. For Judica-Cordiglia brothers nobody will never know what happened as long as Russian will not decide to speak. A third message was recorded on February 2, 1961. Presented to the famous hearth surgeon Dr Dogliotti, he affirmed that we heard an "heavy breathing" and the "fast beating of a dying heart". The Judica-Cordiglia brothers were convinced that Russian didn't shrink from sacrificing human lifes to affirm their supremacy in space. At last, but there are other recordings, on June 14, 1963 our two brothers recorded a female voice alleged to be the one of cosmonaut Valentina Tereshkova. They claim that it was recorded two days before the official launch as declared by the Soviet authorities. The Judica-Cordiglia brothers have gathered many other telemetry and audio recordings, some showing a political importance. On of them was a weak audio signal coming from ground stations, and identified a few times later as classic russian music used by Russian as a coded signal to announce the near launch of a new space mission. And indeed, two days after have recorded this melody, USSR announced the launch of a new space mission. Such information interested much NASA, as well as a russian spy that followed closely the work of our two brothers (but quite rapidly our two brothers were also protected by the italian intelligence services).

Some of these recordings display however a so poor audio quality that well smart the one that could hear an intelligible voice in some of them. The telemetry recordings on the other side are of course much clearer. At first reading, these few examples seem to confirm that our two brothers were witnesses of a conspiracy. If they are persuaded of this, I am not at all like many other people having investigated this affair. In the end, what can we conclude about these documents, and the alleged claims of the Judica-Cordiglia brothers ? This will be the subject of the next chapter.

To be continued...



COMIC'S HAM

Have some fun...



The "little" Shack of... W9EVT



HAM-MAG N.14 - MARCH 2010

Chief Editor : *Vincent Faucheur* F 5 S L D

Design & conception : V.N.A.C.E.

This issue does exist thanks to : EI9GQ, N4PRT, SM3CVM, OPDX, OZ6OM, VK2UW, VK2ZAY, YO2BS, YO6QCZ, ZL3IB, Astrosurf, Dimoni.

Send your informations to : f5sld@free.fr

Website : <http://www.ham-mag.com>

This magazine has been sent to 188 members